



Edition

09/2023

INSTALLATION MANUAL

SINAMICS

SINAMICS G120 converters

PM240-2 Power Modules, IP20

SIEMENS

SINAMICS

SINAMICS G120 Power Module PM240-2

Hardware Installation Manual

<u>Fundamental safety instructions</u>	1
<u>Introduction</u>	2
<u>Installing</u>	3
<u>Connecting</u>	4
<u>Service and maintenance</u>	5
<u>Technical data</u>	6
<u>Spare parts</u>	7
<u>Accessories</u>	8
<u>Appendix</u>	A

Legal information

Warning notice system

This manual contains notices you have to observe in order to ensure your personal safety, as well as to prevent damage to property. The notices referring to your personal safety are highlighted in the manual by a safety alert symbol, notices referring only to property damage have no safety alert symbol. These notices shown below are graded according to the degree of danger.

 DANGER
indicates that death or severe personal injury will result if proper precautions are not taken.

 WARNING
indicates that death or severe personal injury may result if proper precautions are not taken.

 CAUTION
indicates that minor personal injury can result if proper precautions are not taken.

NOTICE
indicates that property damage can result if proper precautions are not taken.

If more than one degree of danger is present, the warning notice representing the highest degree of danger will be used. A notice warning of injury to persons with a safety alert symbol may also include a warning relating to property damage.

Qualified Personnel

The product/system described in this documentation may be operated only by **personnel qualified** for the specific task in accordance with the relevant documentation, in particular its warning notices and safety instructions. Qualified personnel are those who, based on their training and experience, are capable of identifying risks and avoiding potential hazards when working with these products/systems.

Proper use of Siemens products

Note the following:

 WARNING
Siemens products may only be used for the applications described in the catalog and in the relevant technical documentation. If products and components from other manufacturers are used, these must be recommended or approved by Siemens. Proper transport, storage, installation, assembly, commissioning, operation and maintenance are required to ensure that the products operate safely and without any problems. The permissible ambient conditions must be complied with. The information in the relevant documentation must be observed.

Trademarks

All names identified by ® are registered trademarks of Siemens AG. The remaining trademarks in this publication may be trademarks whose use by third parties for their own purposes could violate the rights of the owner.

Disclaimer of Liability

We have reviewed the contents of this publication to ensure consistency with the hardware and software described. Since variance cannot be precluded entirely, we cannot guarantee full consistency. However, the information in this publication is reviewed regularly and any necessary corrections are included in subsequent editions.

Table of contents

1	Fundamental safety instructions.....	7
1.1	General safety instructions.....	7
1.2	Equipment damage due to electric fields or electrostatic discharge	13
1.3	Warranty and liability for application examples.....	13
1.4	Cybersecurity information.....	14
1.5	Residual risks of power drive systems	15
2	Introduction.....	17
3	Installing.....	23
3.1	Installation conditions.....	23
3.2	EMC-compliant installation of a machine or system	25
3.2.1	Control cabinet.....	26
3.2.2	Cables.....	27
3.2.3	Electromechanical components.....	30
3.3	Power losses and air cooling requirements	31
3.4	Mounting the Power Modules	32
3.4.1	Sequence for installing the Power Module.....	33
3.4.2	Dimension drawings and drilling dimensions.....	34
3.4.3	Mounting the shield plates.....	36
3.4.4	Hoisting gear FSD ... FSG.....	40
3.4.5	Additional components.....	40
4	Connecting.....	41
4.1	Permissible line supplies.....	44
4.1.1	TN line system	45
4.1.2	TT line system.....	46
4.1.3	IT system	47
4.1.4	Requirements for the protective conductor.....	48
4.1.5	Fault protection for the motor circuit.....	49
4.1.6	Using several single-phase converters in machines and plants	50
4.2	Connecting the line and motor cable at the converter.....	51
4.2.1	Connection overview	51
4.2.2	Length of the motor cable.....	54
4.2.3	Connection terminals at the converter.....	56
4.2.4	Establishing connections.....	57
4.3	STO via Power Module terminals	62
4.4	Connecting the motor to the converter in a star or delta connection	63

5	Service and maintenance	65
5.1	Maintenance	66
5.2	Installation after a long storage time	67
5.3	Replacing a fan	68
5.3.1	Fan replacement FSA ... FSC	69
5.3.2	Fan replacement FSD ... FSF	70
5.3.3	FSG fan replacement	71
6	Technical data	73
6.1	Electromagnetic compatibility - Overview	74
6.2	Ambient conditions	75
6.3	Overload capability of the converter	76
6.4	Data regarding the power loss in partial load operation	78
6.5	200 V converters	78
6.5.1	General data, 200 V converters	79
6.5.2	Specific technical data, 200 V converters	81
6.5.3	Current derating depending on the pulse frequency, 200 V converters	84
6.6	400 V converters	85
6.6.1	General data, 400 V converters	86
6.6.2	Specific technical data, 400 V converters	88
6.6.3	Current derating depending on the pulse frequency, 400 V converters	93
6.7	690 V converters	95
6.7.1	General data, 690 V converters	96
6.7.2	Specific technical data, 690 V converters	98
6.7.3	Current derating depending on the pulse frequency, 690 V converters	101
6.8	Current rating for DC terminals	102
6.9	Restrictions for special ambient conditions	103
6.10	Electromagnetic compatibility of variable-speed drives	107
6.10.1	Converter applications	108
6.10.1.1	Operation in the Second Environment	108
6.10.1.2	Operation in the First Environment	110
6.10.2	Typical harmonic currents	111
6.10.3	Harmonics at the power supply connection point according to IEC 61000-2-2	112
6.10.4	EMC limit values in South Korea	112
6.11	Protecting persons from electromagnetic fields	113
7	Spare parts	115
8	Accessories	117
8.1	Top shield plate - FSD ... FSG	117
8.2	Control Unit Adapter Kit CUA20	118
8.3	SINAMICS FSG Adapter Set	121
8.4	Line filter	122
8.5	Line harmonics filter	124

8.6	Line reactor	128
8.7	Braking resistor	132
8.7.1	Installing a braking resistor	132
8.7.1.1	Braking resistor for frame sizes FSA ... FSF	132
8.7.1.2	Braking resistor for frame size FSG	135
8.7.2	Connecting a braking resistor.....	136
8.7.3	Technical data of the braking resistor	139
8.8	Brake Relays.....	142
8.8.1	Technical data of the Brake Relay	143
8.8.2	Connections and circuit diagrams.....	143
8.8.3	Mounting and connecting the Brake Relay.....	144
8.9	Output reactor	147
8.10	Sine-wave filter.....	154
8.11	dv/dt filter plus VPL	157
A	Appendix.....	167
A.1	Manuals and technical support.....	167
A.1.1	Manuals for your converter	167
A.1.2	Download a Manual.....	169
A.1.3	Configuring support.....	170
A.1.4	Product Support.....	171
A.2	Directives and standards	172
A.3	Abbreviations	175
	Index.....	177

Fundamental safety instructions

1.1 General safety instructions



WARNING

Electric shock and danger to life due to other energy sources

Touching live components can result in death or severe injury.

- Only work on electrical devices when you are qualified for this job.
- Always observe the country-specific safety rules.

Generally, the following steps apply when establishing safety:

1. Prepare for disconnection. Notify all those who will be affected by the procedure.
2. Isolate the drive system from the power supply and take measures to prevent it being switched back on again.
3. Wait until the discharge time specified on the warning labels has elapsed.
4. Check that there is no voltage between any of the power connections, and between any of the power connections and the protective conductor connection.
5. Check whether the existing auxiliary supply circuits are de-energized.
6. Ensure that the motors cannot move.
7. Identify all other dangerous energy sources, e.g. compressed air, hydraulic systems, or water. Switch the energy sources to a safe state.
8. Check that the correct drive system is completely locked.

After you have completed the work, restore the operational readiness in the inverse sequence.



WARNING

Risk of electric shock and fire from supply networks with an excessively high impedance

Excessively low short-circuit currents can lead to the protective devices not tripping or tripping too late, and thus causing electric shock or a fire.

- In the case of a conductor-conductor or conductor-ground short-circuit, ensure that the short-circuit current at the point where the converter is connected to the line supply at least meets the minimum requirements for the response of the protective device used.
- You must use an additional residual-current device (RCD) if a conductor-ground short circuit does not reach the short-circuit current required for the protective device to respond. The required short-circuit current can be too low, especially for TT supply systems.



! WARNING

Risk of electric shock and fire from supply networks with an excessively low impedance

Excessively high short-circuit currents can lead to the protective devices not being able to interrupt these short-circuit currents and being destroyed, and thus causing electric shock or a fire.

- Ensure that the prospective short-circuit current at the line terminal of the converter does not exceed the breaking capacity (SCCR or Icc) of the protective device used.



! WARNING

Electric shock if there is no ground connection

For missing or incorrectly implemented protective conductor connection for devices with protection class I, high voltages can be present at open, exposed parts, which when touched, can result in death or severe injury.

- Ground the device in compliance with the applicable regulations.



! WARNING

Electric shock due to connection to an unsuitable power supply

When equipment is connected to an unsuitable power supply, exposed components may carry a hazardous voltage. Contact with hazardous voltage can result in severe injury or death.

- Only use power supplies that provide SELV (Safety Extra Low Voltage) or PELV- (Protective Extra Low Voltage) output voltages for all connections and terminals of the electronics modules.



! WARNING

Electric shock due to equipment damage

Improper handling may cause damage to equipment. For damaged devices, hazardous voltages can be present at the enclosure or at exposed components; if touched, this can result in death or severe injury.

- Ensure compliance with the limit values specified in the technical data during transport, storage and operation.
- Do not use any damaged devices.



! WARNING

Electric shock due to unconnected cable shield

Hazardous touch voltages can occur through capacitive cross-coupling due to unconnected cable shields.

- As a minimum, connect cable shields and the conductors of power cables that are not used (e.g. brake cores) at one end at the grounded housing potential.

**! WARNING****Arcing when a plug connection is opened during operation**

Opening a plug connection when a system is in operation can result in arcing that may cause serious injury or death.

- Only open plug connections when the equipment is in a voltage-free state, unless it has been explicitly stated that they can be opened in operation.

**! WARNING****Electric shock due to residual charges in power components**

Because of the capacitors, a hazardous voltage is present for up to 5 minutes after the power supply has been switched off. Contact with live parts can result in death or serious injury.

- Wait for 5 minutes before you check that the unit really is in a no-voltage condition and start work.

NOTICE**Damage to equipment due to unsuitable tightening tools.**

Unsuitable tightening tools or fastening methods can damage the screws of the equipment.

- Only use screw inserts that exactly match the screw head.
- Tighten the screws with the torque specified in the technical documentation.
- Use a torque wrench or a mechanical precision nut runner with a dynamic torque sensor and speed limitation system.
- Adjust the tools used regularly.

NOTICE**Property damage due to loose power connections**

Insufficient tightening torques or vibration can result in loose power connections. This can result in damage due to fire, device defects or malfunctions.

- Tighten all power connections to the prescribed torque.
- Check all power connections at regular intervals, particularly after equipment has been transported.

 **WARNING**

Electromagnetic interference due to inadequate shield support

A lack of adequate shield support for the power cables can cause malfunctions and impermissibly high levels of interference.

- Use the shield connection plates supplied or recommended.
- Use the shield connection clips recommended.

 **WARNING**

Spread of fire from built-in devices

Built-in devices can cause a fire and a pressure wave in the event of a fault. Fire and smoke can escape from the control cabinet and cause serious personal injury and property damage.

- Install built-in appliances in a robust metal control cabinet that is suitable for protecting people from fire and smoke.
- Only operate built-in devices with the control cabinet doors closed.
- Ensure that smoke can only escape via controlled and monitored paths.

 **WARNING**

Active implant malfunctions due to electromagnetic fields

Converters generate electromagnetic fields (EMF) in operation. Electromagnetic fields may interfere with active implants, e.g. pacemakers. People with active implants in the immediate vicinity of an converter are at risk.

- As the operator of an EMF-emitting installation, assess the individual risks of persons with active implants.
- Observe the data on EMF emission provided in the product documentation.

 **CAUTION**

Symptomatic respiratory and skin reaction to chemicals

A newly purchased product might contain traces of substances that are identified as sensitizers.

Sensitizers are substances which can cause sensitization in the lungs and skin after exposure to them.

Once sensitized, individuals can have severe reactions to further exposure, even in small amounts. In the most extreme cases, individuals might develop asthma or dermatitis respectively.

- If the product has a strong smell, keep it in a well-ventilated area for 14 days.

 **WARNING****Unexpected machine movement caused by radio devices or mobile phones**

Using radio devices, cellphones, or mobile WLAN devices in the immediate vicinity of the components can result in equipment malfunction. Malfunctions may impair the functional safety of machines and can therefore put people in danger or lead to property damage.

- Therefore, if you move closer than 20 cm to the components, be sure to switch off radio devices, cellphones or WLAN devices.
- Use the "SIEMENS Industry Online Support App" or a QR code scanner only on equipment that has already been switched off.

NOTICE**Damage to motor insulation due to excessive voltages**

When operated on systems with grounded line conductors or in the event of a ground fault in the IT system, the motor insulation can be damaged by the higher voltage against ground. If you use motors that have insulation that is not designed for operation with grounded line conductors, you must perform the following measures:

- IT system: Use a ground fault monitor and eliminate the fault as quickly as possible.
- TN or TT systems with grounded line conductor: Use an isolating transformer on the line side.

 **WARNING****Fire due to inadequate ventilation clearances**

Inadequate ventilation clearances can cause overheating of components with subsequent fire and smoke. This can cause severe injury or even death. This can also result in increased downtime and reduced service lives for devices/systems.

- Ensure compliance with the specified minimum clearance as ventilation clearance for the respective component.

NOTICE**Overheating due to inadmissible mounting position**

The device may overheat and therefore be damaged if mounted in an inadmissible position.

- Only operate the device in admissible mounting positions.

 **WARNING**

Unrecognized dangers due to missing or illegible warning labels

Dangers might not be recognized if warning labels are missing or illegible. Unrecognized dangers may cause accidents resulting in serious injury or death.

- Check that the warning labels are complete based on the documentation.
- Attach any missing warning labels to the components, where necessary in the national language.
- Replace illegible warning labels.

NOTICE

Device damage caused by incorrect voltage/insulation tests

Incorrect voltage/insulation tests can damage the device.

- Before carrying out a voltage/insulation check of the system/machine, disconnect the devices as all converters and motors have been subject to a high voltage test by the manufacturer, and therefore it is not necessary to perform an additional test within the system/machine.

 **WARNING**

Unexpected movement of machines caused by inactive safety functions

Inactive or non-adapted safety functions can trigger unexpected machine movements that may result in serious injury or death.

- Observe the information in the appropriate product documentation before commissioning.
- Carry out a safety inspection for functions relevant to safety on the entire system, including all safety-related components.
- Ensure that the safety functions used in your drives and automation tasks are adjusted and activated through appropriate parameterizing.
- Perform a function test.
- Only put your plant into live operation once you have guaranteed that the functions relevant to safety are running correctly.

Note

Important Safety instructions for Safety Integrated

If you want to use Safety Integrated functions, you must observe the Safety instructions in the Safety Integrated documentation.

1.2 Equipment damage due to electric fields or electrostatic discharge

Electrostatic sensitive devices (ESD) are individual components, integrated circuits, modules or devices that may be damaged by either electric fields or electrostatic discharge.



NOTICE

Equipment damage due to electric fields or electrostatic discharge

Electric fields or electrostatic discharge can cause malfunctions through damaged individual components, integrated circuits, modules or devices.

- Only pack, store, transport and send electronic components, modules or devices in their original packaging or in other suitable materials, e.g. conductive foam rubber or aluminum foil.
- Only touch components, modules and devices when you are grounded by one of the following methods:
 - Wearing an ESD wrist strap
 - Wearing ESD shoes or ESD grounding straps in ESD areas with conductive flooring
- Only place electronic components, modules or devices on conductive surfaces (table with ESD surface, conductive ESD foam, ESD packaging, ESD transport container).

1.3 Warranty and liability for application examples

Application examples are not binding and do not claim to be complete regarding configuration, equipment or any eventuality which may arise. Application examples do not represent specific customer solutions, but are only intended to provide support for typical tasks.

As the user you yourself are responsible for ensuring that the products described are operated correctly. Application examples do not relieve you of your responsibility for safe handling when using, installing, operating and maintaining the equipment.

1.4 Cybersecurity information

Siemens provides products and solutions with industrial cybersecurity functions that support the secure operation of plants, systems, machines and networks.

In order to protect plants, systems, machines and networks against cyber threats, it is necessary to implement – and continuously maintain – a holistic, state-of-the-art industrial cybersecurity concept. Siemens' products and solutions constitute one element of such a concept.

Customers are responsible for preventing unauthorized access to their plants, systems, machines and networks. Such systems, machines and components should only be connected to an enterprise network or the internet if and to the extent such a connection is necessary and only when appropriate security measures (e.g. firewalls and/or network segmentation) are in place.

For additional information on industrial cybersecurity measures that may be implemented, please visit

<https://www.siemens.com/global/en/products/automation/topic-areas/industrial-cybersecurity.html>.

Siemens' products and solutions undergo continuous development to make them more secure. Siemens strongly recommends that product updates are applied as soon as they are available and that the latest product versions are used. Use of product versions that are no longer supported, and failure to apply the latest updates may increase customer's exposure to cyber threats.

To stay informed about product updates, subscribe to the Siemens Industrial Cybersecurity RSS Feed under

<https://new.siemens.com/global/en/products/services/cert.html>.

Further information is provided on the Internet:

Industrial Security Configuration Manual

(<https://support.industry.siemens.com/cs/ww/en/view/108862708>)

WARNING

Unsafe operating states resulting from software manipulation

Software manipulations, e.g. viruses, Trojans, or worms, can cause unsafe operating states in your system that may lead to death, serious injury, and property damage.

- Keep the software up to date.
- Incorporate the automation and drive components into a state-of-the-art, integrated industrial cybersecurity concept for the installation or machine.
- Make sure that you include all installed products in the integrated industrial cybersecurity concept.
- Protect files stored on exchangeable storage media from malicious software by with suitable protection measures, e.g. virus scanners.
- Carefully check all cybersecurity-related settings once commissioning has been completed.

1.5 Residual risks of power drive systems

When assessing the machine or system-related risk in accordance with the respective local regulations (e.g. EC Machinery Directive), the machine manufacturer or system integrator must take into account the following residual risks emanating from the control and drive components of a drive system:

1. Unintentional movements of driven machine or system components during commissioning, operation, maintenance, and repairs caused by, for example,
 - Hardware faults and/or software errors in the sensors, control system, actuators, and connections
 - Response times of the control system and of the drive
 - Operation and/or environmental conditions outside the specification
 - Condensation/conductive contamination
 - Parameterization, programming, cabling, and installation errors
 - Use of wireless devices/mobile phones in the immediate vicinity of electronic components
 - External influences/damage
 - X-ray, ionizing radiation and cosmic radiation
2. Unusually high temperatures inside and outside the components, including open flames, as well as emissions of light, noise, particles, gases, etc. due to fault conditions, e.g.:
 - Component failure
 - Software errors
 - Operation and/or environmental conditions outside the specification
 - External influences/damage
 - Short circuits or ground faults in the intermediate DC circuit of the converter
3. Hazardous shock voltages caused by, for example:
 - Component failure
 - Influence during electrostatic charging
 - Induction of voltages in moving motors
 - Operation and/or environmental conditions outside the specification
 - Condensation/conductive contamination
 - External influences/damage
4. Electrical, magnetic and electromagnetic fields generated in operation that can pose a risk to people with a pacemaker, implants or metal replacement joints, etc., if they are too close
5. Release of environmental pollutants or emissions as a result of improper operation of the system and/or failure to dispose of components safely and correctly

1.5 Residual risks of power drive systems

6. Influence of network-connected and wireless communications systems, e.g. ripple-control transmitters or data communication via the network or mobile radio, WLAN or Bluetooth.

7. Motors for use in potentially explosive areas:

When moving components such as bearings become worn, this can cause enclosure components to exhibit unexpectedly high temperatures during operation, creating a hazard in areas with a potentially explosive atmosphere.

For more information about the residual risks of the drive system components, see the relevant sections in the technical user documentation.

Introduction

Overview

The Power Modules belong to the modular family of SINAMICS G120 converters. A modular converter comprises a Control Unit and a Power Module.

Depending on the power rating in frame sizes FSA ... FSG, the following Power Module versions are supplied:

- 1 AC 200 V 0.55 kW ... 4 kW for line voltages from 1 AC 200 V ... 240 V
- 3 AC 200 V 0.55 kW ... 55 kW for line voltages from 3 AC 200 V ... 240 V
- 3 AC 400 V 0.55 kW ... 250 kW for line voltages from 3 AC 380 V ... 480 V
- 3 AC 690 V 11 kW ... 250 kW for line voltages from 3 AC 500 V ... 690 V

Article numbers overview

200 V converters

200 V	Rated out-put power (kW)	Rated out-put current (A)	Variant	Article number	
Frame size	Based on Low Overload (LO)			Without filter	With filter
FSA	0.55	3.2	IP20	6SL3210-1PB13-0ULO	6SL3210-1PB13-0ALO
	0.75	4.2	IP20	6SL3210-1PB13-8ULO	6SL3210-1PB13-8ALO
FSB	1.1	6	IP20	6SL3210-1PB15-5ULO	6SL3210-1PB15-5ALO
	1.5	7.4	IP20	6SL3210-1PB17-4ULO	6SL3210-1PB17-4ALO
	2.2	10.4	IP20	6SL3210-1PB21-0ULO	6SL3210-1PB21-0ALO
FSC	3	13.6	IP20	6SL3210-1PB21-4ULO	6SL3210-1PB21-4ALO
	4	17.5	IP20	6SL3210-1PB21-8ULO	6SL3210-1PB21-8ALO
	5.5	22	IP20	6SL3210-1PC22-2ULO	6SL3210-1PC22-2ALO
	7.5	28	IP20	6SL3210-1PC22-8ULO	6SL3210-1PC22-8ALO
FSD	11	42	IP20	6SL3210-1PC24-2ULO	-
	15	54	IP20	6SL3210-1PC25-4ULO	-
	18.5	68	IP20	6SL3210-1PC26-8ULO	-
FSE	22	80	IP20	6SL3210-1PC28-0ULO	-
	30	104	IP20	6SL3210-1PC31-1ULO	-
FSF	37	130	IP20	6SL3210-1PC31-3ULO	-
	45	154	IP20	6SL3210-1PC31-6ULO	-
	55	178	IP20	6SL3210-1PC31-8ULO	-

400 V converters

400 V	Rated out-put power (kW)	Rated out-put current (A)	Variant	Article number	
Frame size	Based on Low Overload (LO)			Without filter	With filter
FSA	0.55	1.7	IP20	6SL3210-1PE11-8UL1	6SL3210-1PE11-8AL1
	0.75	2.2	IP20	6SL3210-1PE12-3UL1	6SL3210-1PE12-3AL1
	1.1	3.1	IP20	6SL3210-1PE13-2UL1	6SL3210-1PE13-2AL1
	1.5	4.1	IP20	6SL3210-1PE14-3UL1	6SL3210-1PE14-3AL1
	2.2	5.9	IP20	6SL3210-1PE16-1UL1	6SL3210-1PE16-1AL1
	3	7.7	IP20	6SL3210-1PE18-0UL1	6SL3210-1PE18-0AL1
FSB	4	10.2	IP20	6SL3210-1PE21-1ULO	6SL3210-1PE21-1ALO
	5.5	13.2	IP20	6SL3210-1PE21-4ULO	6SL3210-1PE21-4ALO
	7.5	18	IP20	6SL3210-1PE21-8ULO	6SL3210-1PE21-8ALO
FSC	11	26	IP20	6SL3210-1PE22-7ULO	6SL3210-1PE22-7ALO
	15	32	IP20	6SL3210-1PE23-3ULO	6SL3210-1PE23-3ALO
FSD	18.5	38	IP20	6SL3210-1PE23-8ULO	6SL3210-1PE23-8ALO
	22	45	IP20	6SL3210-1PE24-5ULO	6SL3210-1PE24-5ALO
	30	60	IP20	6SL3210-1PE26-0ULO	6SL3210-1PE26-0ALO
	37	75	IP20	6SL3210-1PE27-5ULO	6SL3210-1PE27-5ALO
FSE	45	90	IP20	6SL3210-1PE28-8ULO	6SL3210-1PE28-8ALO
	55	110	IP20	6SL3210-1PE31-1ULO	6SL3210-1PE31-1ALO
FSF	75	145	IP20	6SL3210-1PE31-5ULO	6SL3210-1PE31-5ALO
	90	178	IP20	6SL3210-1PE31-8ULO	6SL3210-1PE31-8ALO
	110	205	IP20	6SL3210-1PE32-1ULO	6SL3210-1PE32-1ALO
	132	250	IP20	6SL3210-1PE32-5ULO	6SL3210-1PE32-5ALO
FSG	160	302	IP20	-	6SL3210-1PE33-0CLO ¹⁾
				-	6SL3210-1PE33-0ALO ²⁾
	200	370	IP20	-	6SL3210-1PE33-7CLO ¹⁾
				-	6SL3210-1PE33-7ALO ²⁾
	250	477	IP20	-	6SL3210-1PE34-8CLO ¹⁾
				-	6SL3210-1PE34-8ALO ²⁾

1) with filter class C3

2) with filter class C2

690 V converters

690 V	Rated output power (kW)	Rated output current (A)	Variant	Article number	
Frame size	Based on Low Overload (LO)			Without filter	With filter
FSD	11	14	IP20	6SL3210-1PH21-4ULO	6SL3210-1PH21-4ALO
	15	19	IP20	6SL3210-1PH22-0ULO	6SL3210-1PH22-0ALO
	18.5	23	IP20	6SL3210-1PH22-3ULO	6SL3210-1PH22-3ALO
	22	27	IP20	6SL3210-1PH22-7ULO	6SL3210-1PH22-7ALO
	30	35	IP20	6SL3210-1PH23-5ULO	6SL3210-1PH23-5ALO
	37	42	IP20	6SL3210-1PH24-2ULO	6SL3210-1PH24-2ALO
FSE	45	52	IP20	6SL3210-1PH25-2ULO	6SL3210-1PH25-2ALO
	55	62	IP20	6SL3210-1PH26-2ULO	6SL3210-1PH26-2ALO
FSF	75	80	IP20	6SL3210-1PH28-0ULO	6SL3210-1PH28-0ALO
	90	100	IP20	6SL3210-1PH31-0ULO	6SL3210-1PH31-0ALO
	110	115	IP20	6SL3210-1PH31-2ULO	6SL3210-1PH31-2ALO
	132	142	IP20	6SL3210-1PH31-4ULO	6SL3210-1PH31-4ALO
FSG	160	171	IP20	-	6SL3210-1PH31-7CLO
	200	208	IP20	-	6SL3210-1PH32-1CLO
	250	250	IP20	-	6SL3210-1PH32-5CLO

Control Units for the Power Modules

You can operate the Power Modules with a Control Unit from one of the following listed families:

- CU230P-2
- CU240B-2
- CU240E-2
- CU250S-2

For Power Modules FSA ... FSC, you require a Control Unit with firmware version V4.4 or higher.

For Power Modules FSD ... FSF, you require a Control Unit with firmware version V4.7 HF8 or higher.

For Power Modules FSG, you require a Control Unit with firmware version V4.7 SP9 or higher.

Further information about the available firmware versions is provided on the Internet:

 FAQ (<https://support.industry.siemens.com/cs/ww/en/view/67364620>)

Note

The I/O on the Control Unit may not be connected directly to a mains supply voltage like 200 V, 400 V or 690 V.

Note

Commissioning the converter

You must first commission the converter before you can use it. Commissioning is described in the Operating Instructions of the relevant Control Unit.

 Manuals for your converter (Page 167)

STO independent of the Control Unit

Using the PM240-2 Power Modules, frame sizes FSD, FSE, FSF and FSG, you can implement the "Safe Torque Off" safety function (STO), corresponding to PL e according to EN 13849-1 and SIL 3 according to IEC61508.

 STO via Power Module terminals (Page 62)

Note that when using the STO function, the mission time of the converter is restricted. For more information, see the "Safety Integrated" Function Manual.

 Manuals for your converter (Page 167)

Permissible motors

Note

Motors for converter operation

Only use motors that are suitable for operation with converters with a DC link.

Further information is provided on the Internet:

 FAQ (<https://support.industry.siemens.com/cs/ww/en/view/100426622>)

Motors for 200 V Power Modules

For the 200 V Power Modules, induction motors are permissible in the range from 25% ... 150% of the converter power without any restrictions.

Motors for 400 V Power Modules

For the 400 V Power Modules, induction motors are permissible in the range from 25 % ... 150 % of the converter power without any restrictions.

Motors for 690 V Power Modules

For the 690 V Power Modules, induction motors are permissible in the range from 50 % ... 150 % of the converter power without any restrictions.

Continuous development within the scope of product maintenance

Converter components are being continuously developed within the scope of product maintenance. Product maintenance includes, for example, measures to increase the ruggedness or hardware changes which become necessary as components are discontinued.

These further developments are "spare parts-compatible" and do not change the article number.

In the scope of such spare parts-compatible ongoing development, plug connector or connection positions are sometimes slightly modified. This does not cause any problems when the components are properly used. Please take this fact into consideration in special installation situations (e.g. allow sufficient reserve regarding the cable length).

Intended use

The products described in this manual, together with software, accessories, and options, form an electrical power drive system intended to feed low-voltage AC motors.

The products are professional equipment for stationary indoor use in industrial, light-industrial, and commercial applications and are intended for supply from public and non-public (industrial) low-voltage distribution networks. The products are not intended for use in residential areas.

The products must be transported and stored properly and must be installed, commissioned, and maintained by professionals with sufficient knowledge to implement the safety and EMC measures according to the specifications described in this manual and the recognized state of the art.

You may only use the products in compliance with the following requirements:

- All regulations and directives that are applicable at the site of the end use, especially with regard to electrical safety, functional safety and electromagnetic compatibility.
- All instructions, notes, technical data and safety information contained in this document and other supporting documentation.

The products are used as a component of a machine or plant. You must ensure the safety of persons and property and the electromagnetic compatibility by appropriate system design measures.

You must perform a risk assessment of the entire application including third-party products and implement sufficient safety measures before using the product.

Open type products (IP00 / IP20) are intended for incorporation within control panels or cabinets which will provide necessary protection.

Any application not explicitly permitted is excluded from the warranty and can result in unanticipated hazards.



WARNING

Death or severe personal injury due to unintended use

Applications outside the intended use can lead to dangerous conditions.

- Observe the above notes on intended use.

Note

The compliance with the EMC emission limits cannot be guaranteed if the products are connected to an isolated, or high-impedance earthed, or corner grounded distribution network.





- Create an EMC plan to meet the EMC requirements of the intended application.
-

Installing



3.1 Installation conditions

General installation conditions

When installing the Power Modules carefully observe the conditions listed below in order to guarantee reliable, continuous and disturbance-free operation.

- The Power Modules are designed for installation in a control cabinet.
- The Power Modules are certified for use in environments with degree of pollution 2 without condensation, i.e. in environments where no conductive pollution/dirt occurs.
- The built-in units fulfill IP20 degree of protection at delivery status with the maximum cross section for the connected cables.
- Fast temperature changes of the air drawn in (e.g. by using cooling units) are not permitted due to the risk of condensation.
- Condensation is not permissible when switching on.
- You can find the permissible conductor cross-sections for the terminals in:
 -  Connection terminals at the converter (Page 56)
- The following section describes how you can install the Power Module in compliance with EMC regulations:
 -  EMC-compliant installation of a machine or system (Page 25)
- For a system configuration in conformance with IEC, use the fuse types approved for IEC, specified in the Technical data, or the circuit breakers under the following Internet address.
 -  Fuse types: Technical data (Page 73)
 -  Circuit breaker
(<https://support.industry.siemens.com/cs/ww/en/view/109801083>)

Converters for systems in the United States / Canada (UL/cUL)

- For a system configuration in conformance with UL/cUL, use the fuse types approved for UL/cUL, specified in the Technical data, or the circuit breakers under the following Internet address.
 -  Fuse types: Technical data (Page 73)
 -  Circuit breaker
(<https://support.industry.siemens.com/cs/ww/en/view/109801083>)
- For multi-motor operation, observe the additional preconditions and restrictions provided on the Internet:
 -  Multi-motor operation
(<https://support.industry.siemens.com/cs/ww/en/view/84049346>)
- The integrated semiconductor short-circuit protection does not provide cable protection.
- On the system side, provide **cable protection** in conformance with NEC or CEC, Part 1 and the local regulations.
- The converters provide internal motor protection corresponding to UL61800-5-1.
Protection threshold:
 - 115% of the rated motor current entered for frame sizes FSA ... FSF
 - 120% of the rated motor current entered for frame size FSGYou enter the motor data values and the protection functions when commissioning the converter. Please observe the details in the associated operating instructions.
- Use suitable UL-listed (ZMVV) ring lugs to connect the power terminals of frame sizes FSF and FSG.
- Carefully note that for plants and systems in conformance with UL/cUL, the line and output voltage may not be higher than 600 V.
- Only use copper cables rated for 60 °C or 75 °C.
- FSE, IP20: Only use cables that are certified for temperatures of 75 °C to connect the braking resistor.
- The converters are Open Type devices.

3.2 EMC-compliant installation of a machine or system

The converter is designed for operation in industrial environments where strong electromagnetic fields are to be expected.

Reliable and disturbance-free operation is only ensured for EMC-compliant installation.

To achieve this, subdivide the control cabinet and the machine or system into EMC zones:

EMC zones

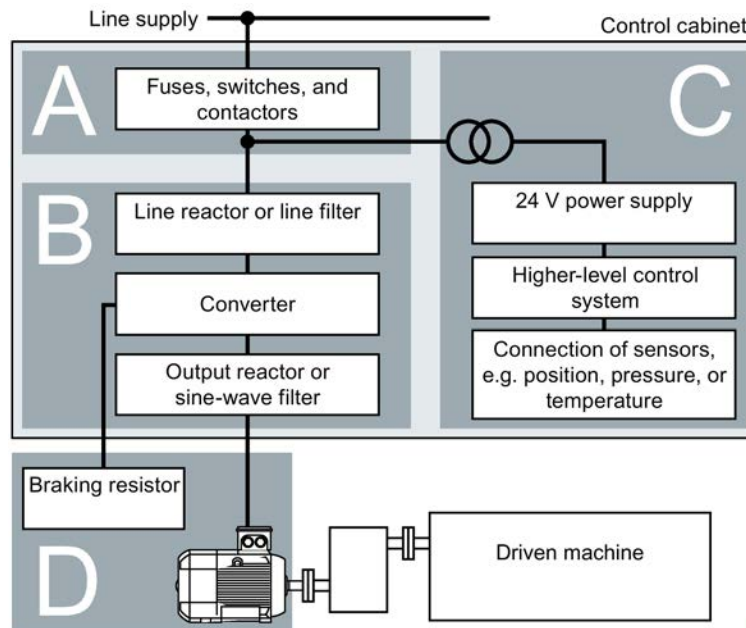

Figure 3-1 Example of the EMC zones of a plant or machine

Inside the control cabinet

- Zone A: Line supply connection
- Zone B: Power electronics
Devices in Zone B generate energy-rich electromagnetic fields.
- Zone C: Control and sensors
Devices in Zone C do not generate any energy-rich electromagnetic fields themselves, but their functions can be impaired by electromagnetic fields.

Outside the control cabinet

- Zone D: Motors, braking resistors
Devices in Zone D generate electromagnetic fields with a significant amount of energy

3.2.1 Control cabinet

- Assign the various devices to zones in the control cabinet.
- Electromagnetically uncouple the zones from each other by means of one of the following actions:
 - Side clearance ≥ 25 cm
 - Separate metal enclosure
 - Large-area partition plates
- Route cables of various zones in separate cable harnesses or cable ducts.
- Install filters or isolation amplifiers at the interfaces of the zones.

Control cabinet assembly

- Connect the door, side panels, top and base plate of the control cabinet with the control cabinet frame using one of the following methods:
 - Electrical contact surface of several cm^2 for each contact location
 - Several screw connections
 - Short, finely stranded, braided copper wires with cross-sections $\geq 95 \text{ mm}^2 / 000 (3/0) (-2)$ AWG
- Install a shield support for shielded cables that are routed out of the control cabinet.
- Connect the PE bar and the shield support to the control cabinet frame through a large surface area to establish a good electrical connection.
- Mount the control cabinet components on a bare metal mounting plate.
- Connect the mounting plate to the control cabinet frame and PE bar and shield support through a large surface area to establish a good electrical connection.
- For screw connections onto painted or anodized surfaces, establish a good conductive contact using one of the following methods:
 - Use special (serrated) contact washers that cut through the painted or anodized surface.
 - Remove the insulating coating at the contact locations.

Measures required for several control cabinets

- Install equipotential bonding for all control cabinets.
- Screw the frames of the control cabinets together at several locations through a large surface area using serrated washers to establish a good electrical connection.
- In plants and systems where the control cabinets are lined up next to one another, and which are installed in two groups back to back, connect the PE bars of the two cabinet groups at as many locations as possible.

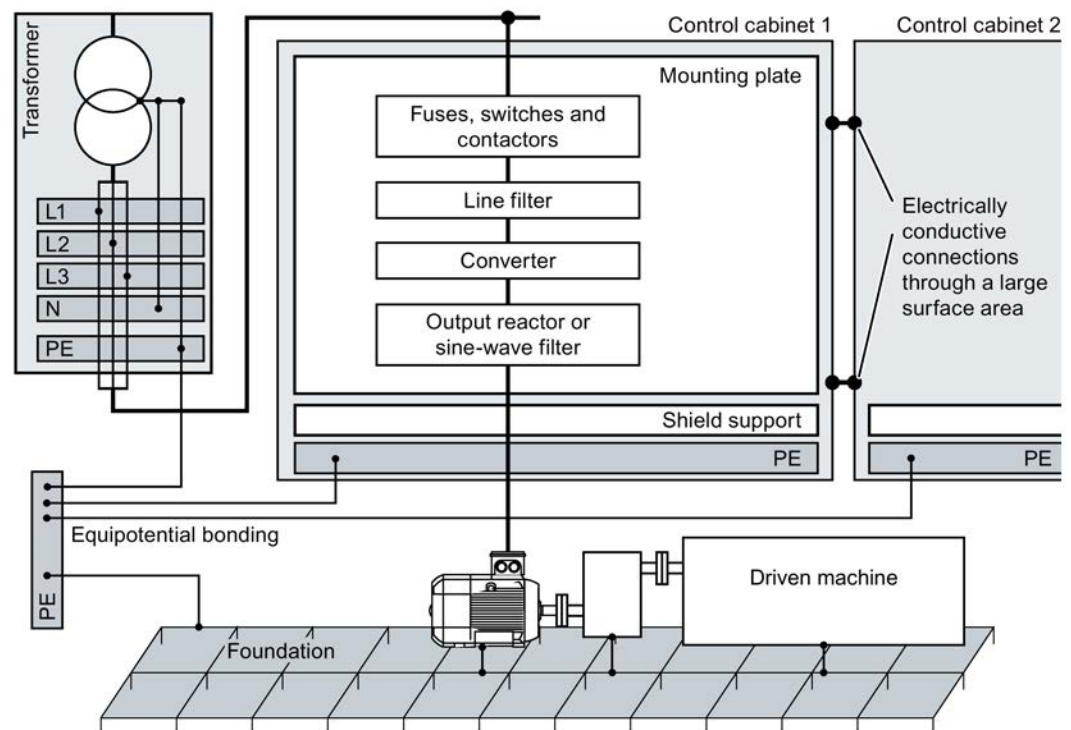

Figure 3-2 Grounding and high-frequency equipotential bonding measures in the control cabinet and in the plant/system

Further information

Additional information about EMC-compliant installation is available in the Internet:



EMC installation guideline

(<http://support.automation.siemens.com/WW/view/en/60612658>)

3.2.2 Cables

Cables with a high level of interference and cables with a low level of interference are connected to the converter:

- Cables with a high level of interference:
 - Cable between the line filter and converter
 - Motor cable
 - Cable at the converter DC link connection
 - Cable between the converter and braking resistor
- Cables with a low level of interference:
 - Cable between the line and line filter
 - Signal and data cables

Cable routing inside the cabinet

- Route the power cables with a high level of interference so that there is a minimum clearance of 25 cm to cables with a low level of interference.

If the minimum clearance of 25 cm is not possible, insert separating metal sheets between the cables with a high level of interference and cables with a low level of interference. Connect these separating metal sheets to the mounting plate to establish a good electrical connection.

- Cables with a high level of interference and cables with a low level of interference may only cross over at right angles:
- Keep all of the cables as short as possible.
- Route all of the cables close to the mounting plates or cabinet frames.
- Route signal and data cables - as well as the associated equipotential bonding cables - parallel and close to one another.
- Twist incoming and outgoing unshielded individual conductors.

Alternatively, you can route incoming and outgoing conductors in parallel, but close to one another.

- Ground any unused conductors of signal and data cables at both ends.
- Signal and data cables must only enter the cabinet from one side, e.g. from below.
- Use shielded cables for the following connections:
 - Cable between the converter and line filter
 - Cable between the converter and output reactor or sine-wave filter

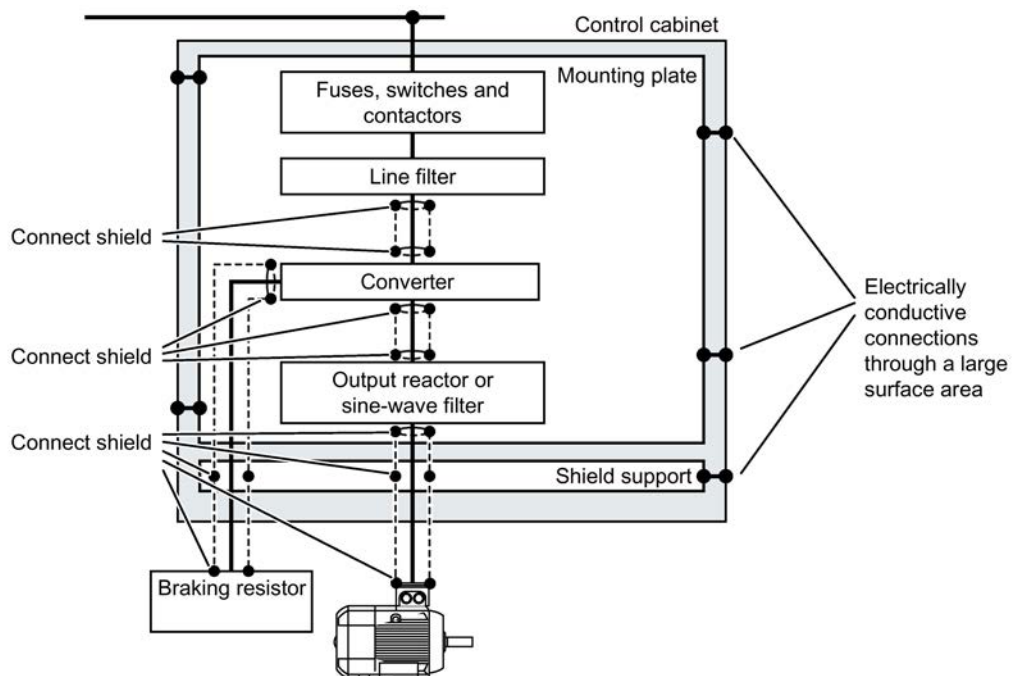

Figure 3-3 Routing converter cables inside and outside a control cabinet

Routing cables outside the control cabinet

- Maintain a minimum clearance of 25 cm between cables with a high level of interference and cables with a low level of interference.
- Use shielded cables for the following connections:
 - Converter motor cable
 - Cable between the converter and braking resistor
 - Signal and data cables
- Connect the motor cable shield to the motor enclosure using a PG gland that establishes a good electrical connection.

Requirements relating to shielded cables

- Use cables with finely-stranded, braided shields.
- Connect the shield to at least one end of the cable.

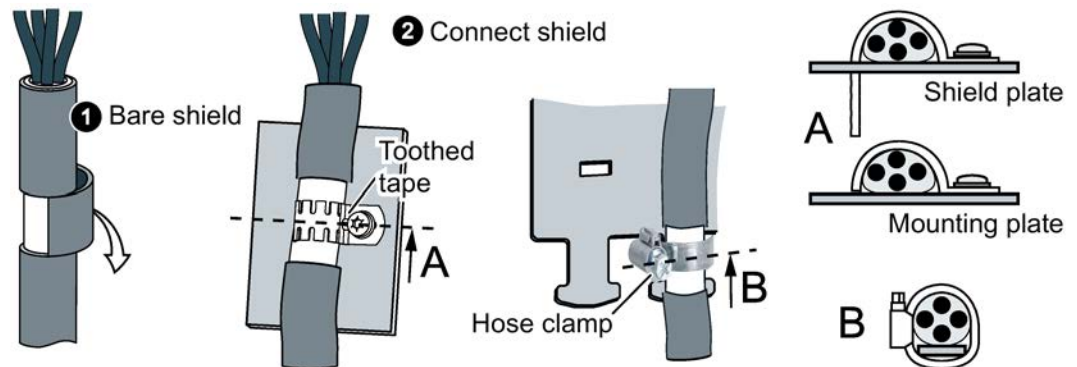

Figure 3-4 Examples for EMC-compliant shield support

- Attach the shield to the shield support directly after the cable enters the cabinet.
- Do not interrupt the shield.
- Only use metallic or metallized plug connectors for shielded data cables.

3.2.3 Electromechanical components

Surge voltage protection circuit

- Connect surge voltage protection circuits to the following components:
 - Coils of contactors
 - Relays
 - Solenoid valves
 - Motor holding brakes
- Connect the surge voltage protection circuit directly at the coil.
- Use RC elements or varistors for AC-operated coils and freewheeling diodes or varistors for DC-operated coils.

3.3 Power losses and air cooling requirements

Cooling requirements

To protect the components from overheating, the control cabinet requires a cooling air flow, which depends on the power loss of the individual components.

Formula for calculating the cooling airflow:

$$\text{airflow [l/s]} = \text{power loss [W]} * 0.86 / \Delta T \text{ [K]}$$

- Power loss: Total of the power losses of the individual components.
- ΔT : Permissible temperature rise in the control cabinet

Measures in order to ensure that the components are adequately cooled

- Add the power losses of the individual components.
 - Power Module data:  "Technical data (Page 73)".
 - The Control Unit power loss is less than 0.04 kW.
 - Use the manufacturers data for components, for example reactors or filters
- Calculate the air flow required, using the formula above.
- Ensure that the control cabinet is appropriately ventilated and equipped with suitable air filters.
- Ensure that the components maintain the specified clearances with respect to one another.

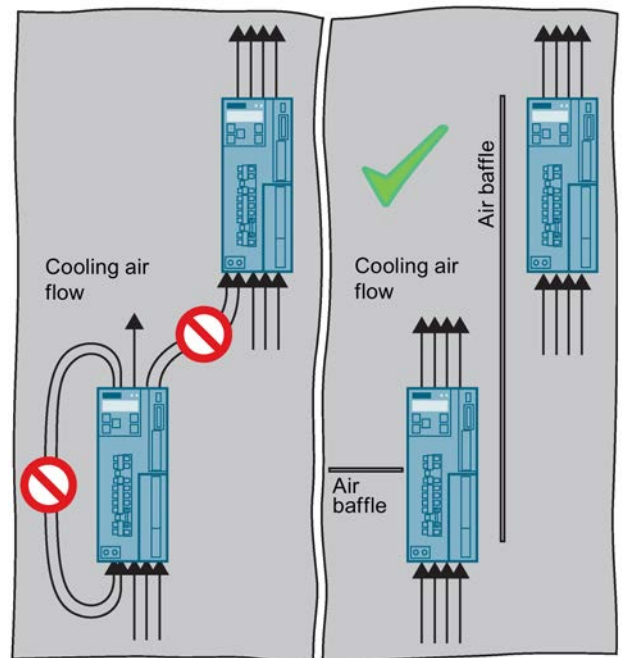

- Ensure that the components are provided with adequate cooling air through the cooling openings.
- Use the appropriate air barriers to prevent cooling air short circuits

Further information

Further information about the power loss in partial load operation, see Chapter "Data regarding the power loss in partial load operation (Page 78)".

3.4 Mounting the Power Modules

Take note of the following listed specifications when installing the Power Module.

Protection against the spread of fire

The device may be operated only in closed housings or in control cabinets with protective covers that are closed, and when all of the protective devices are used. The installation of the device in a metal control cabinet or the protection with another equivalent measure must prevent the spread of fire and emissions outside the control cabinet.

Protection against condensation or electrically conductive contamination

Protect the device, e.g. by installing it in a control cabinet with degree of protection IP54 according to IEC 60529 or NEMA 12. Further measures may be necessary for particularly critical operating conditions.

If condensation or conductive pollution can be excluded at the installation site, a lower degree of control cabinet protection may be permitted.

Installing

Rules for admissible mounting:

- Only mount the Power Module in a vertical position with the motor connectors at the bottom.

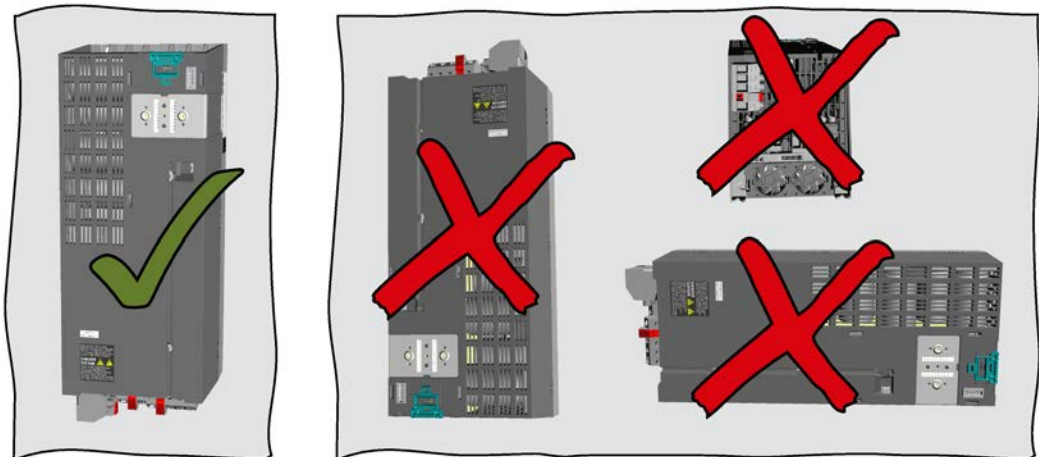

- Maintain the minimum clearances to other components.
- Use the specified installation parts and components.
- Comply with the specified torques.

3.4.1 Sequence for installing the Power Module

During installation, comply with the sequence listed below.

Frame sizes FSA ... FSC

1. Prepare the cabinet.
2. Mount the shield plates.
3. Install the Power Module.
4. If you are using a Brake Relay or Safe Brake Relay:
Install the Brake Relay next to the converter.

Frame sizes FSD ... FSG

1. Prepare the cabinet.
2. If you are using a Brake Relay or Safe Brake Relay:
Install the Brake Relay on the rear side of the shield plate.
3. Mount the shield plates.
4. Install the Power Module.

3.4.2 Dimension drawings and drilling dimensions

The following dimension drawings and drilling patterns are not to scale.

Frame sizes FSA ... FSC

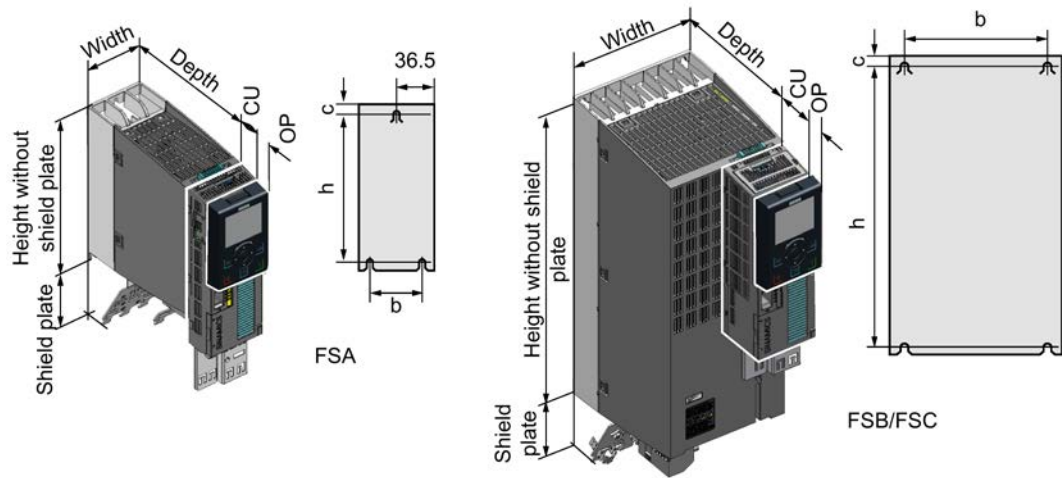

Table 3-1 Dimensions depend on the Control Unit (CU) and HMI device [mm]

Frame size	Width [mm]	Height [mm]		Depth [mm]			
		without shield plate	with shield plate	without CU	with CU230P-2 ¹⁾	with CU240B-2 ¹⁾ / CU240E-2 ¹⁾	with CU250S-2 ¹⁾
FSA	73	196	276	165	224	206	227
FSB	100	292	370	165	224	206	227
FSC	140	355	432	165	224	206	227

¹⁾ With SINAMICS G120 Smart Access plus 9 mm; with blanking cover or with Operator Panel plus 11 mm

Table 3-2 Drilling dimensions, cooling clearances and fixing

Frame size	Drilling dimensions [mm]			Cooling air clearances [mm] ¹⁾			Fixing/torque [Nm]
	h	b	c	Top	Bottom	Front	
FSA	186	62.3	6	80	100	100	3 x M4 / 2.5
FSB	281	80	6	80	100	100	4 x M4 / 2.5
FSC	343	120	6	80	100	100	4 x M5 / 3.5

¹⁾ The Power Module is designed for mounting without any lateral cooling air clearance. For tolerance reasons, we recommend a lateral clearance of approx. 1 mm.

Frame sizes FSD ... FSG

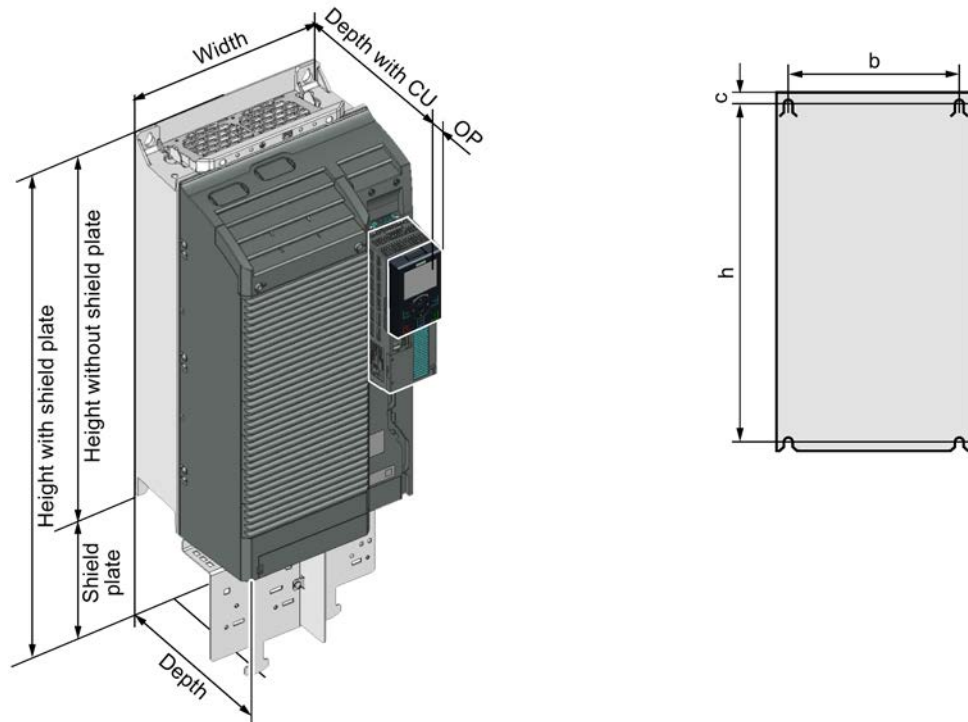

Table 3-3 Dimensions depend on the Control Unit (CU) and HMI device [mm]

Frame size	Width [mm]	Height [mm]		Depth [mm]			
		without shield plate	with shield plate	without CU	with CU230P-2 ¹⁾	with CU240B-2 ¹⁾ / CU240E-2 ¹⁾	with CU250S-2 ¹⁾
FSD	200	472	624	237	253	237	256
FSE	275	551	728	237	253	237	256
FSF	305	709	966	357	373	357	376
FSG	305	1000	1255	357	373	357	376

¹⁾ With SINAMICS G120 Smart Access plus 9 mm; with blanking cover or with Operator Panel plus 11 mm

Table 3-4 Drilling dimensions, cooling clearances and fixing

Frame size	Drilling dimensions [mm]			Cooling air clearances [mm] ¹⁾			Fixing/torque [Nm]
	h	b	c	Top ²⁾	Bottom ²⁾	Front	
FSD	430	170	7	300	350	100	4 x M5 / 6.0
FSE	509	230	8.5	300	350	100	4 x M6 / 10
FSF	680	270	13	300	350	100	4 x M8 / 25
FSG	970.5	265	15	300	350	100	4 x M10 / 50

¹⁾ The Power Module is designed for mounting without any lateral cooling air clearance. For tolerance reasons, we recommend a lateral clearance of approx. 1 mm.

²⁾ The top and bottom cooling air clearances refer to the Power Module without shield plate.

3.4.3 Mounting the shield plates

Use the provided shield plate for strain relief of the line and motor cable – as well as the shield support for the motor cable.

The shield plates and fixings screws are included in the converter accessory kit.

Mounting the shield plate, FSA ... FSC

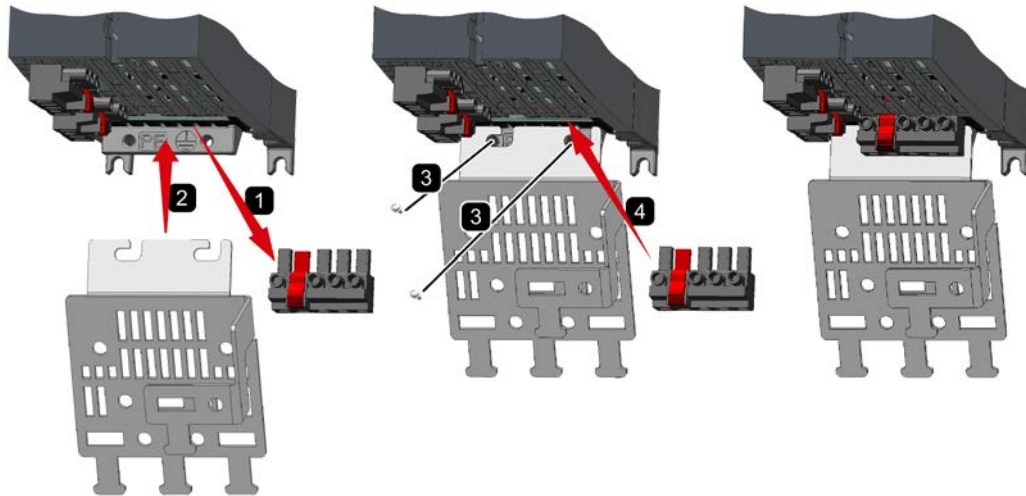

Note

Upper shield plate

The top shield plate is not supplied with the converter. You need it as a shield support when you connect an external braking resistor.

 Braking resistor (Page 132)

EMC connecting bracket

The EMC connecting bracket is only supplied with converters with integrated filter.

Mounting the shield plate, FSD and FSE

Proceed as follows to mount the shield plate:

- If you are using a Brake Relay to control a motor holding brake, then mount the Brake Relay at the rear of the shield plate.

 Mounting and connecting the Brake Relay (Page 144)

- **If the device has an integrated line filter:**

Fasten the EMC connecting bracket to the shield plate using four screws ①.

Then slide the shield plate with the EMC connecting bracket into the converter, so that it is held in the converter by the clamping spring ②.

The EMC connecting bracket is positioned correctly if there is some resistance when it is withdrawn from the converter.

Having ensured that it is positioned correctly, fasten the shield plate in place using the four screws ③.

- **If the device is unfiltered:**

Having ensured that it is positioned correctly, fasten the shield plate in place using the four screws ③.

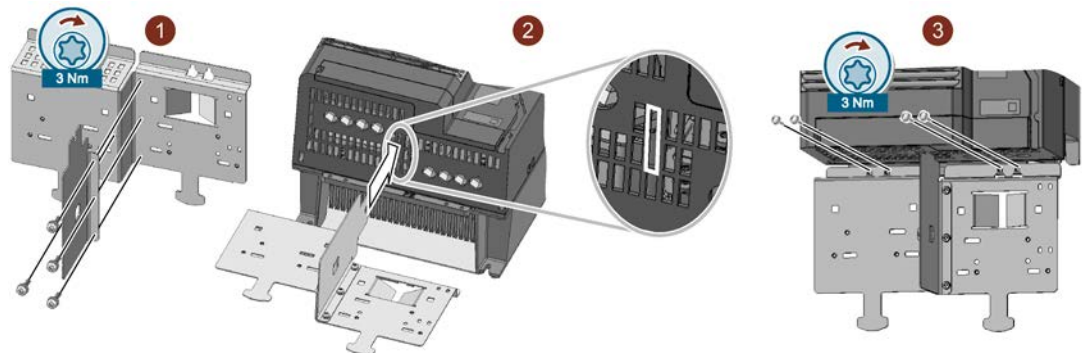

Use the shield plate provided for strain relief of the line and motor cable – as well as the shield support for the motor cable.

If you are using the converter without filter, then you do not require the EMC connecting bracket. In this case, attach the shield plate to the converter without the EMC connecting bracket

If you are using a converter with integrated line filter, then mount the shield plate and EMC connecting bracket as described below.

Note

Brake relay

If you are using a Brake Relay to control a motor brake, then mount the Brake Relay at the rear of the lower shield plate before you attach the shield module to the converter.

 Mounting and connecting the Brake Relay (Page 144)

FSD and FSE

Proceed as follows to mount the EMC connecting bracket and the shield plate:

Procedure

1. Attach the EMC connecting bracket to the shield plate ①.
2. Then slide the shield module into the converter, so that it is held in the converter ② by the clamping spring. The shield module is located correctly if it can be easily withdrawn out of the converter without any resistance.
3. After you have ensured that it is correctly located, fix the shield module using the four screws ③.

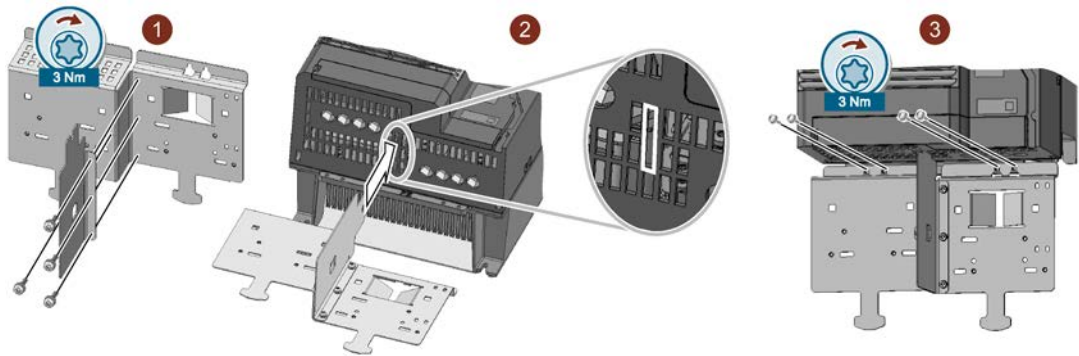

You have correctly mounted the EMC connecting bracket and the shield plate.



FSF

Proceed as follows to mount the EMC connecting bracket and the shield plate:

Procedure

1. Attach the EMC connecting bracket to the shield plate ①.
2. Screw the shield module to the converter ② using three screws, as shown in the diagram.

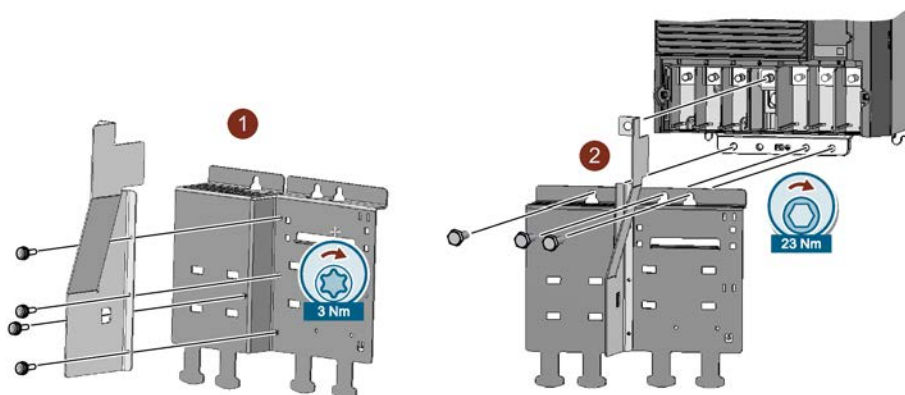

You have correctly mounted the EMC connecting bracket and the shield plate.



Mounting the shield plate, FSG

Proceed as follows to mount the shield plate:

- If you are using a Brake Relay to control a motor holding brake, then mount the Brake Relay at the rear of the shield plate.

 Mounting and connecting the Brake Relay (Page 144)

- Secure each side part to the shield plate with two screws ①.
- Fasten the EMC connecting bracket to the shield plate with four screws ②.
- Screw the shield plate to the converter together with the side parts and EMC connecting bracket using four screws ③

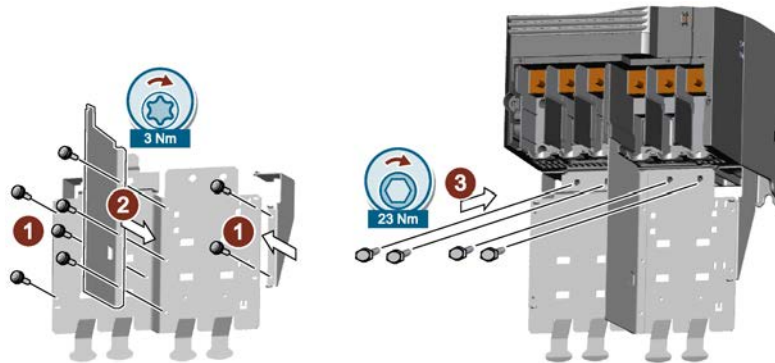

3.4.4 Hoisting gear FSD ... FSG

Power Module weights:

 200 V converter (Page 81)

 400 V converter (Page 88)

 690 V converter (Page 98)

Hoisting gear

Use crane lifting lugs and the appropriate hoisting gear when mounting built-in devices.

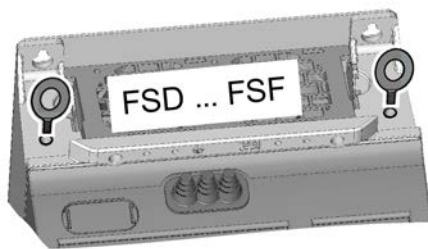

3.4.5 Additional components

Depending on the particular application, additional components may be required for your system. Information about additional components is provided in the following Sections:

 Connection overview (Page 51)

 Accessories (Page 117)

Install the converter so that you are compliant with local regulations for erecting and installing low-voltage systems.

Note**Safety devices**

Install suitable protective equipment between the line supply and converter.



Technical data (Page 73)

Note**Operating displays for converter operation**

If, when switching over a function from ON to OFF, an LED or other similar display is not lit or not active; this does not indicate that the device is switched-off or in a no-current condition.

Observe the following product note about protection against indirect contact:

 To protect against indirectly touching part of the motor circuit of a converter and to automatically shut down in the case of a fault according to DIN EN 60364-4-41 (VDE 0100-410). (<http://support.automation.siemens.com/WW/view/en/103474630>)

**! WARNING****Electrical shock due to inadequate touch protection**

Due to faulty contact protection, the power connections of the converter may be openly accessible. Touching live power connections can result in death or severe injury.

- Make the openings for the converter power connections just large enough for the cables to be routed through.
- Cover power connections that are not used so that they cannot be touched.
- Use the dummy plugs provided in the accessory pack for unused terminals.

**! WARNING****Fire or electric shock due to unsuitable residual-current protective devices**

The converter may create a current through the protective conductor. The current through the protective conductor can cause the residual current device (RCD) or residual current monitor (RCM) to incorrectly trip (nuisance trip). In the case of a ground fault, the fault current can contain a DC component, which prevents the RCD or RCM from tripping, with the risk of subsequent fire or electric shock.

- Use the protection and monitoring devices recommended in the documentation.

**! CAUTION****Burns due to touching hot surfaces**

Certain components (e.g. the heat sink or line reactor) can become very hot during operation. The components can remain hot for some time after operation. Touching hot surfaces can cause burns to the skin.

- Do not touch hot components during operation or immediately following operation.

Caution

In a residential environment, this product may cause radio interference in which case supplementary mitigation measures may be required.

Protection and monitoring equipment

To provide protection against short-circuit, use the overcurrent devices listed in Technical data (fuses, circuit breakers etc.).

If the earth fault loop impedance of the line supply at the infeed point is too high to ensure that the overcurrent protective device disconnects within the stipulated time in the case of insulation failure (ground fault, fault to frame), then you must use additional residual current protective devices RCD, type B.

In order that an RCD does not unnecessarily trip as a result of operational leakage currents, the following preconditions must be fulfilled:

- The neutral point of the line supply is grounded.
- For converters with rated input currents ≤ 80 A referred to LO, use a Siemens SIQUENCE RCCB (series 5SV364.-4), type B, short-time delayed [K] with a rated residual current of 300 mA. Connect the RCCB in series with the overcurrent protective devices.
- For converters with rated input currents ≤ 160 A referred to LO, use a Siemens residual current device RCD520B (3VA9113-ORL21) mounted onto a Siemens molded case circuit breaker (series 3VA1).

Recommended settings:

- Response characteristic B
- Residual current trip level 300 mA
- Response delay ≥ 0.06 s

- For converters with rated input currents > 160 A referred to LO, use a Siemens modular RCCB device (MRCD type B 5SV8111-4KK) with a current transformer (5SV870.-2K), a circuit breaker (series 3VA1) and a trip element (3VA9988-0BL30).

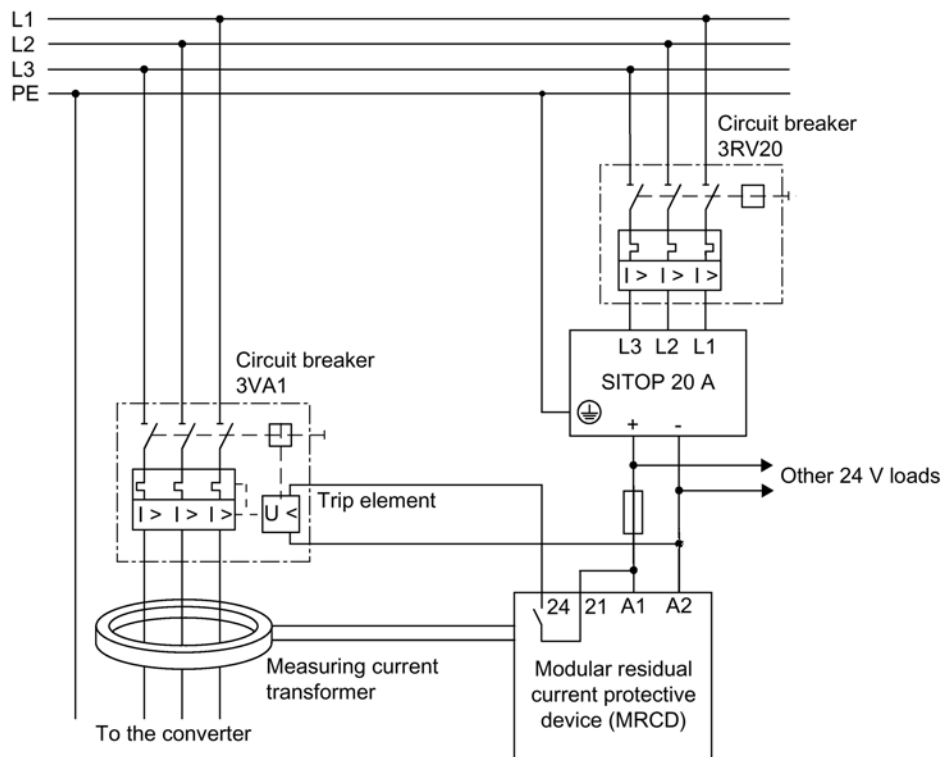

Figure 4-1 MRCD

- A dedicated RCD is used for every converter.
- The motor cables are shorter than 50 m (164 ft) shielded, or 100 m (328 ft) unshielded.
Additional information about motor cables:
➡ Length of the motor cable (Page 54)

You can find information about other permissible overcurrent protection devices on the Internet

🌐 Further protection and monitoring equipment
(<https://support.industry.siemens.com/cs/ww/en/view/109801083>)

4.1 Permissible line supplies

The converter is designed for the following line supplies according to IEC 60364-1 (2005).

- TN system
- TT system
- IT system

Note

FSA ... FSF unfiltered variants and FSG C3 filtered variants (after removing the screw for functional grounding) of all voltage ratings (200 V ... 240 V, 380 V ... 480 V, and 500 V ... 690 V) are permitted to be used on line systems with grounded line conductor (690 V converter variants can be operated with a maximum line voltage of 600 V).

General requirements on line supply

The plant builder or machine manufacturer must ensure for operation with rated current I_{rated} that the voltage drop between the transformer input terminals and the converter when operated with its rated values is less than 4% of the transformer rated current

Restrictions for installation altitudes above 2000 m

Above an installation altitude of 2000 m, the permissible line supplies are restricted.



Restrictions for special ambient conditions (Page 103)

Screw for functional grounding on the converter, frame size FSG

If you wish to use the converters with integrated C3 line filter, please note the information in the sections "TN line system", "TT line system" and "IT system" below.

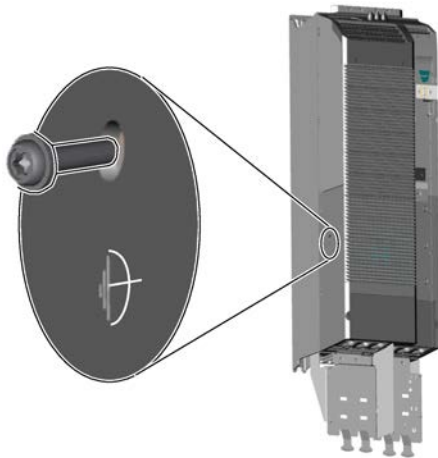

Figure 4-2 Remove screw for functional grounding

4.1.1 TN line system

A TN system transfers the PE protective conductor to the installed plant or system using a cable.

Generally, in a TN system the neutral point is grounded. There are versions of a TN system with a grounded line conductor, e.g. with grounded L1.

A TN system can transfer the neutral conductor N and the PE protective conductor either separately or combined.

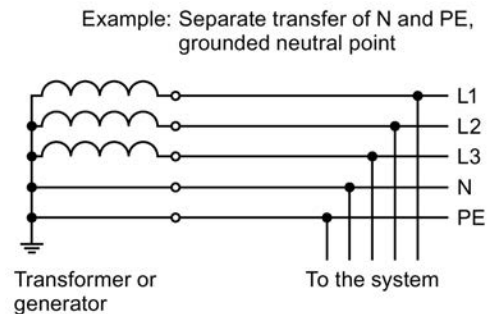

Converter connected to a TN system

- Converters with integrated line filter:
 - Operation on TN line systems with grounded neutral point permissible.
 - Operation on TN line systems with grounded line conductor not permissible.

Note

Special feature of FSG converters

FSG converters with integrated C3 line filter can be operated in TN line systems ≤ 600 V with a grounded line conductor if you remove the screw for functional grounding.

 Figure 4-2 Remove screw for functional grounding (Page 44)

If you remove the screw for functional grounding, the EMC properties deteriorate and the requirements of Class C3 are no longer met.

- Converters with external line filter:
 - Operation on TN line systems with grounded neutral point permissible.
 - Operation on TN line systems with grounded line conductor not permissible.
- Converter without line filter:
 - Operation on all TN line systems ≤ 600 V permissible.
 - Operation on TN line systems (> 600 V and ≤ 690 V) and grounded neutral point permissible; applicable only to 690 V converters.
 - Operation on TN line systems > 600 V and grounded line conductor not permissible.

4.1.2 TT line system

In a TT line system, the transformer grounding and the installation grounding are independent of one another.

There are TT line supplies where the neutral conductor N is either transferred – or not.

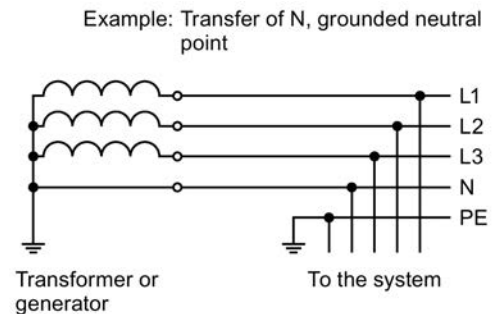

Note

Operation in IEC or UL systems

For installations in compliance with IEC, operation on TT line systems is permissible. For installations in compliance with UL, operation on TT line systems is not permissible.

Converters connected to a TT system

- Converters with integrated line filter:
 - Operation on TT line systems with grounded neutral point permissible.
 - Operation on TT line systems without grounded neutral point not permissible.

Note

Special feature of FSG converters

FSG converters with integrated C3 line filter can be operated in TT line systems without a grounded neutral point if you remove the screw for functional grounding.

 Figure 4-2 Remove screw for functional grounding (Page 44)

If you remove the screw for functional grounding, the EMC properties deteriorate and the requirements of Class C3 are no longer met.

- Converters with external line filter:
 - Operation on TT line systems with grounded neutral point permissible.
 - Operation on TT line systems without grounded neutral point not permissible.
- Converters without line filter:
 - Operation on all TT line systems ≤ 600 V permissible.
 - Operation on TT line systems (> 600 V and ≤ 690 V) and grounded neutral point permissible; applicable only to 690 V converters.
 - Operation on TT line systems > 600 V and grounded line conductor not permissible.

4.1.3 IT system

In an IT line system, all of the conductors are insulated with respect to the PE protective conductor – or connected to the PE protective conductor through an impedance.

There are IT systems with and without transfer of the neutral conductor N.

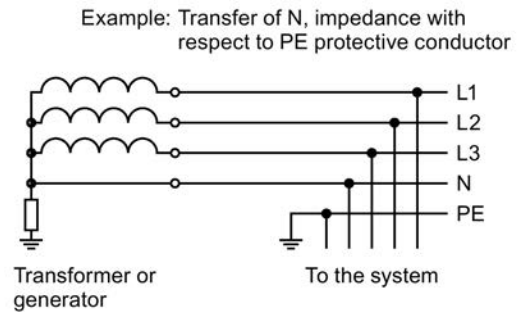

Note

Behavior of the converter when a ground fault occurs

If the converter is to remain operable even when a ground fault occurs at the converter output, you must install an output reactor. This prevents an overcurrent trip or damage to the drive.

Converters connected to an IT system

- Converters with integrated line filter:
 - Operation on IT line systems not permissible.

Note

Special feature of FSG converters

FSG converters with integrated C3 line filter can be operated in IT line systems if you remove the screw for functional grounding.

 Figure 4-2 Remove screw for functional grounding (Page 44)

If you remove the screw for functional grounding, the EMC properties deteriorate and the requirements of Class C3 are no longer met.

- Converters without line filter:
 - Operation on all IT line systems permissible.

Note

690 V converters: Output reactors for frame sizes FSD and FSE

An output reactor is required for 690 V reactors in frame sizes FSD and FSE.

4.1.4 Requirements for the protective conductor

Overview

A high leakage current flows through the protective conductor in converter operation. The protective conductor of the converter must not be interrupted for safe touch protection in converter operation.

This primarily results in requirements for the minimum conductor cross-section of the protective conductor.

No restriction applies to the length of the protective conductor for touch protection. However, short protective conductors are advantageous for EMC-compliant installation.

Description



! WARNING

Electric shock due to interrupted protective conductor

The drive components conduct a high leakage current via the protective conductor. Touching conductive parts when the protective conductor is interrupted can result in death or serious injury.

- Comply with the requirements for the protective conductor.

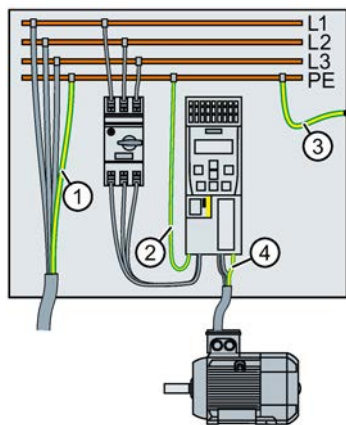

- ① Protective conductor for line feeder cables
- ② Protective conductor for converter line feeder cables
- ③ Protective conductor between PE and the control cabinet
- ④ Protective conductor for motor feeder cables

The minimum cross-section of the protective conductor ① ... ④ depends on the cross-section of the line or motor feeder cable:

- Line or motor feeder cable $\leq 16 \text{ mm}^2$
⇒ Minimum cross-section of the protective conductor = cross-section of the line or motor feeder cable
- $16 \text{ mm}^2 < \text{line or motor feeder cable} \leq 35 \text{ mm}^2$
⇒ Minimum cross-section of the protective conductor = 16 mm^2
- Line or motor feeder cable $> 35 \text{ mm}^2$
⇒ Minimum cross-section of the protective conductor = $\frac{1}{2}$ cross-section of the line or motor feeder cable

Additional requirements placed on the protective conductor ① according to IEC 60204-1:

- For permanent connection, the protective conductor must fulfill at least one of the following conditions:
 - The protective conductor is routed so that it is protected against damage along its complete length.
Cables routed inside switch cabinets or enclosed machine housings are considered to be adequately protected against mechanical damage.
 - As a conductor of a multi-conductor cable, the protective conductor has a cross-section $\geq 2.5 \text{ mm}^2 \text{ Cu}$.
 - For an individual conductor, the protective conductor has a cross-section $\geq 10 \text{ mm}^2 \text{ Cu}$.
 - The protective conductor consists of 2 individual conductors with the same cross-section.
- When connecting a multi-core cable using an industrial plug connector according to EN 60309, the protective conductor must have a cross-section of $\geq 2.5 \text{ mm}^2 \text{ Cu}$.
- Observe the local regulations for protective conductors subject to a high leakage current at the installation site.

4.1.5 Fault protection for the motor circuit

Description

The converter provides short-circuit protection at the motor output terminals.

The manufacturer's declaration describes the conditions regarding protection against electric shock in the event of an insulation failure in the motor circuit.

More information

You can find more information on the Internet: Manufacturer's declaration (<https://support.industry.siemens.com/cs/cn/en/view/109476638>)

4.1.6 Using several single-phase converters in machines and plants

Overview

Evaluate the input currents of single-phase converters in your machine or plant in terms of harmonics and unbalance.

Description

In unfavorable cases, the harmonic currents of several converters in the neutral conductor (N) add up to a value greater than the currents of the line conductors (L1, L2, L3). The current-carrying capacity of the neutral conductor must be sufficient for this. IEC 60364-5-52:2019, section 524, makes recommendations for sizing the neutral conductor. If no more precise information is available, the standard recommends dimensioning the neutral conductor for 1.45 times the current-carrying capacity of the line conductors.

 **WARNING**

Fire caused by neutral conductor (N) overload

The neutral conductor can heat up due to the load from harmonic currents and cause a fire.

- Consider the harmonic currents when dimensioning the neutral conductor.



 **WARNING**

Electric shock caused by PEN conductor overload

In TN-C supply networks, the protective function of the PEN conductor can be adversely affected by exposure to harmonic currents.

- Consider the harmonic currents when dimensioning the PEN conductor.

4.2 Connecting the line and motor cable at the converter

4.2.1 Connection overview

Note

Line reactor

No line reactor is required for FSD ... FSG Power Modules.

Line filter

The converters are available with or without integrated line filter (Class A). For frame sizes FSA ... FSC, 3 AC 400 V, there are external filters (Class B regarding conducted emissions) for increased EMC requirements.

 Line filters (Page 122)

Line harmonics filter

If you use a line harmonics filter you do not need a line reactor or a line filter.

 Line harmonics filters (Page 124)

Output reactor

For frame sizes FSD ... FSG no output reactor is required in many cases on account of the long cable lengths between the converter and the motor.

 Output reactors (Page 147)

Braking resistor

Connect a braking resistor to the converter via the R1 and R2 terminals.

 Braking resistors (Page 132)

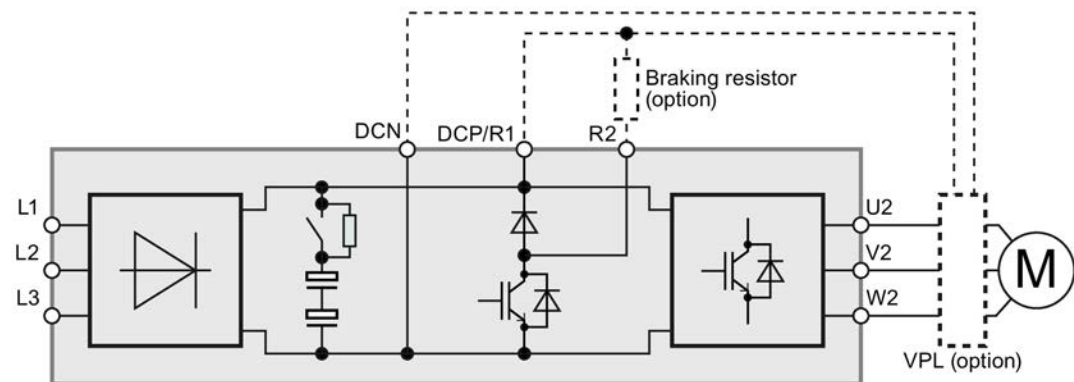

Figure 4-3 Block diagram of the converter, FSA ... FSC

4.2 Connecting the line and motor cable at the converter

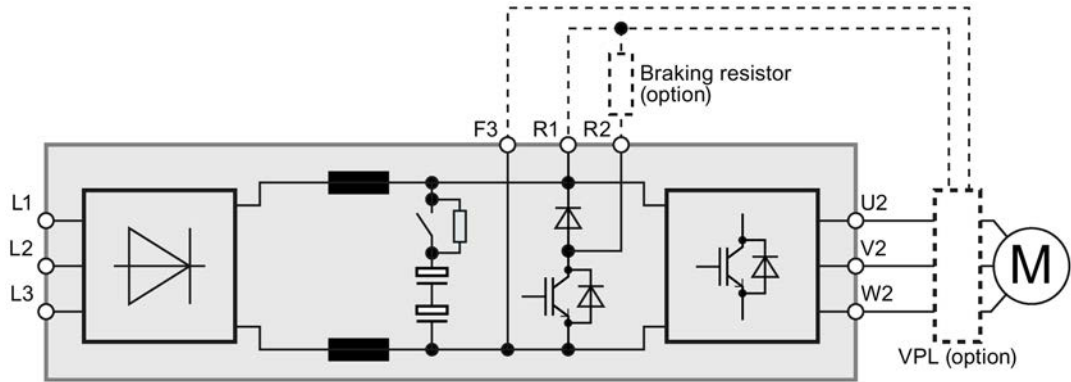

Figure 4-4 Block diagram for the converter, FSD ... FSG

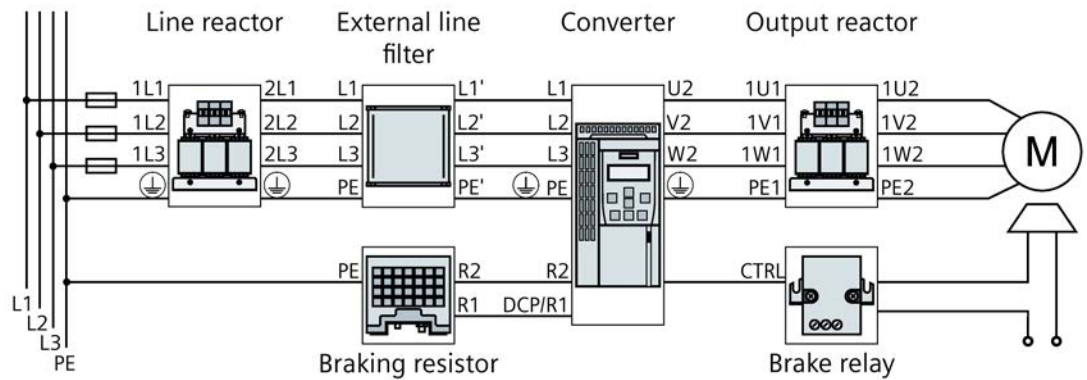

Figure 4-5 Connecting the PM240-2 Power Module, 200 V / 400 V 3 AC, FSA ... FSC

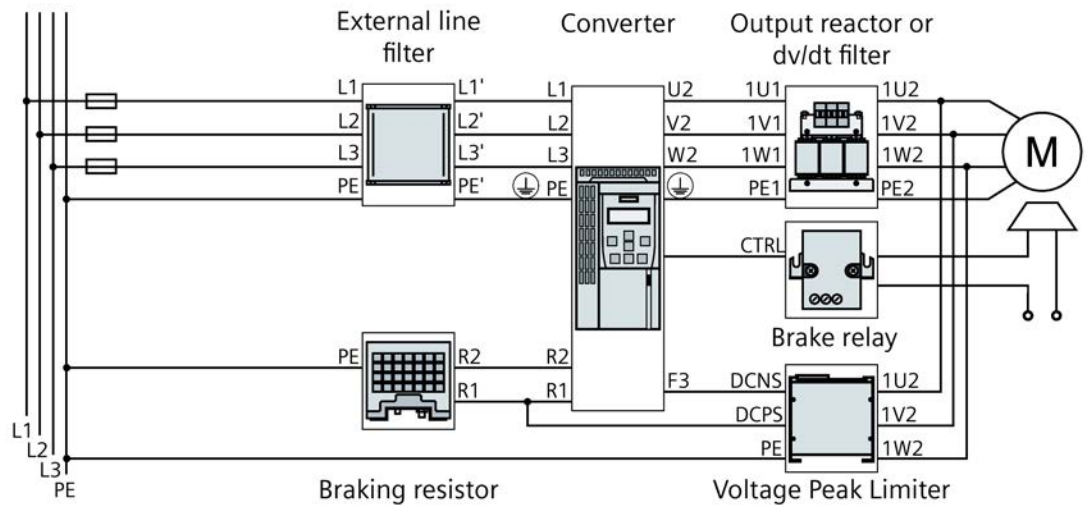

Figure 4-6 Connecting the PM240-2 Power Module, 200 V / 400 V / 690 V 3 AC, FSD ... FSG

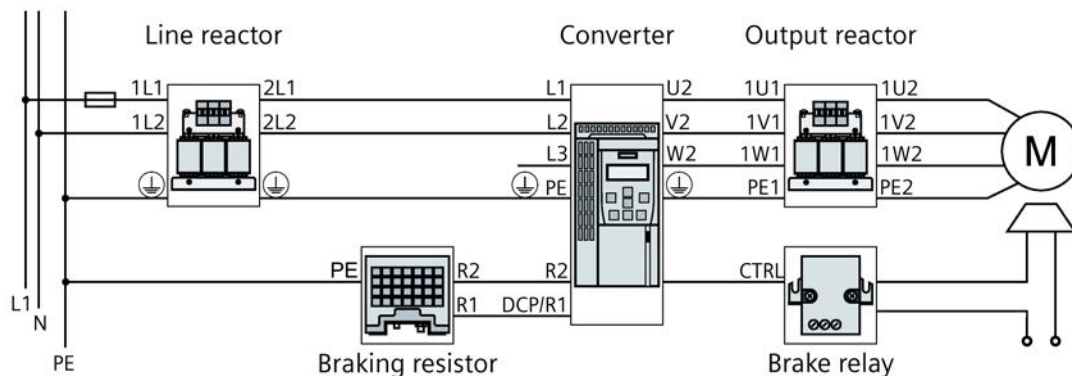

Figure 4-7 Connecting the PM240-2 Power Module, 200 V 1 AC, FSA ... FSC

Note

Connecting PM240-2 Power Modules, 200 V to 1 AC - only FSA ... FSC

For the 200 V versions and single-phase line systems, connect the phase conductor and neutral conductor to any two of the terminals L1, L2, L3.

Connect cables at the converter so that they are EMC compliant

Attach the cable tie holders to the Power Module as shown to the left in the diagram before you establish the connections.

Fix the line connecting cable using a cable tie as shown in ①.

Fix the shield of the motor connecting cable using a hose clamp ②).

Connect the shield of the control cable with the shield plate of the Control Unit ③) using a steel band. Also attach the control cable to the Power Module using a cable tie ④).

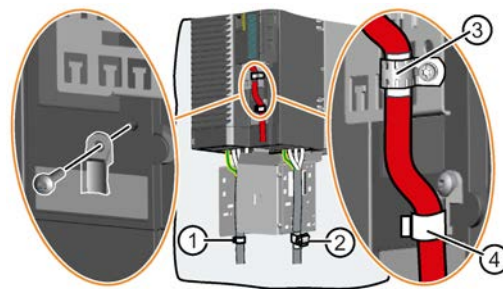

4.2.2 Length of the motor cable

Always dimension the motor cable so that the ohmic losses are less than 5 % of the converter power rating.

The permissible length of the motor cable also depends on the quality of the motor cable and the converter pulse frequency. The values specified below are applicable for high quality cables, such as CY100 or similar, and for the pulse frequencies set in the factory.

 Technical data (Page 73)

If you set other pulse frequencies, then you must ensure that the EMC category is complied with on the plant or system side.

EMC-compliant wiring is required in order that the converter complies with the EMC category listed in the following table.

 EMC-compliant installation of a machine or system (Page 25)

Carefully observe the following section for operation in the first environment:

 Electromagnetic compatibility of variable-speed drives (Page 107)

Table 4- 1 Permissible lengths of motor connecting cables, converter FSA ... FSC

EMC category	Second Environment, C2			No EMC category		
	with internal C2 filter	with external C1 filter, without output reactor	with external C1 filter, with output reactor	without filter, without output reactor	without filter, with output reactor	
Cable	Shielded	Shielded	Shielded	Shielded/unshielded	Shielded	Unshielded
200 V	50 m	50 m	---	150 m	150 m	225 m
400 V	50 m ¹⁾	50 m ²⁾	150 m ³⁾	150 m	150 m ³⁾	225 m ⁴⁾

¹⁾ For a low-capacitance motor cable: FSB 100 m, FSC 150 m

²⁾ For a low-capacitance motor cable: FSA 150 m, FSB 100 m, FSC 100 m

³⁾ 150 m for voltages in the range 380 V ... 415 V,
100 m for voltages in the range 440 V ... 480 V

⁴⁾ 225 m for voltages in the range 380 V ... 415 V,
150 m for voltages in the range 440 V ... 480 V

Table 4- 2 Permissible cable lengths for the motor connection, FSD ... FSE

EMC category	Second Environment, C2	No EMC category			
Converter	with internal C2 filter	with or without filter, with or without output reactor		without filter, with two output reactors in series	
Cable	Shielded	Shielded	Unshielded	Shielded	Unshielded
200 V	150 m	200 m	300 m	350 m	525 m
400 V	150 m	200 m	300 m	350 m	525 m
690 V	100 m	200 m	300 m	---	---

Table 4- 3 Permissible cable lengths for the motor connection, FSF

EMC category	Second Environment, C2	No EMC category			
Converter	with internal C2 filter	with or without filter, with or without output reactor		without filter, with two output reactors in series	
Cable	Shielded	Shielded	Unshielded	Shielded	Unshielded
200 V	150 m	300 m	450 m	525 m	800 m
400 V	150 m	300 m	450 m	525 m	800 m
690 V	150 m ¹⁾	300 m	450 m	525 m	800 m

¹⁾ only C3



Table 4- 4 Permissible cable lengths for the motor connection, FSG

EMC category	Second Environment, C2	No EMC category			
Converter	with internal C2 filter	with or without filter, with or without output reactor		without filter, with two output reactors in series	
Cable	Shielded	Shielded	Unshielded	Shielded	Unshielded
400 V	150 m 300 m ¹⁾	300 m	450 m	525 m	800 m
690 V	300 m ¹⁾	300 m	450 m	525 m	800 m

¹⁾ only C3

4.2.3 Connection terminals at the converter

Table 4- 5 Connection, cross-section and tightening torque for PM240-2 Power Modules

Converter	Connection		Cross-section and tightening torque		Stripped insulation length
			Metric	Imperial	
FSA	Line system, motor and braking resistor	 Plug connector with screw terminals	1.5 ... 2.5 mm ² , 0.5 Nm	16 ... 14 AWG, 4.5 lbf in	8 mm
FSB			1.5 ... 6 mm ² , 0.6 Nm	16 ... 10 AWG, 5.5 lbf in	8 mm
FSC			6 ... 16 mm ² , 1.3 Nm	10 ... 6 AWG, 12 lbf in	10 mm
FSD	Line and motor	Screw-type terminal	10 ... 35 mm ² , 2.5 ... 4.5 Nm	8 ... 2 AWG, 22 ... 40 lbf in	18 mm
	Braking resistor		2.5 ... 16 mm ² , 1.2 ... 1.5 Nm	14 ... 6 AWG, 10.5 ... 13 lbf in	10 mm
FSE	Line and motor	Screw-type terminal	25 ... 95 mm ² , 8 ... 10 Nm	4 ... 3/0 AWG, 71 ... 88.5 lbf in	25 mm
	Braking resistor		10 ... 35 mm ² , 2.5 ... 4.5 Nm	8 ... 2 AWG, 22 ... 40 lbf in	18 mm
FSF	Line and motor	 Cable lug according to SN71322 for M10 bolts	35 ... 2 × 120 mm ² , 22 ... 25 Nm	2 ... 2 × 4/0 AWG, 195 ... 221 lbf.in	/
	Braking resistor	Screw-type terminal	25 ¹⁾ ... 95 mm ² , 8 ... 10 Nm	4 ... 3/0 AWG, 71 ... 88.5 lbf in	25 mm
FSG	Line and motor	 Cable lug according to SN71322 for M10 bolts	35 ... 2 × 185 mm ² , 22 ... 25 Nm	2 AWG ... 2 × 350 kcmil, 195 ... 221 lbf.in	/
	Braking resistor	Screw-type terminal	25 ... 95 mm ² , 8 ... 10 Nm	4 ... 3/0 AWG, 71 ... 88.5 lbf in	25 mm

¹⁾ 16 mm² allowed during short-time duty

4.2.4 Establishing connections

Procedure

1. Ensure that the device is in a no-voltage condition and the DC link is discharged.
2. Establish the connections as described in the following sections.

You have established the connections.



Connections for frame sizes FSA ... FSC

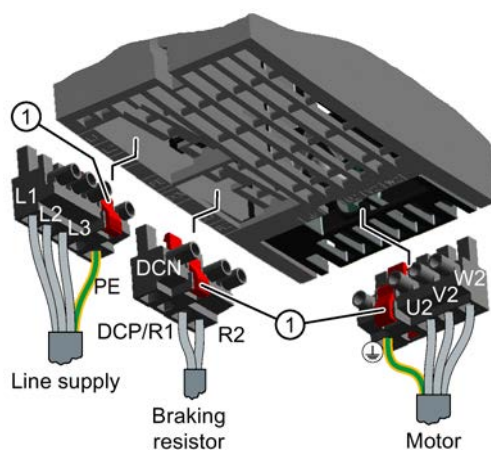

The Power Modules are equipped with withdrawable plug connectors that cannot be inadvertently interchanged.

To remove a plug connector, you must release it by pressing on the red lever.

- ① Release lever

Connections for frame sizes FSD ... FSG

You must remove the covers from the connections in order to connect the line supply, braking resistor and motor to the converter.

In addition, for frame sizes FSD and FSE, release the two terminal screws on the connections for the motor and braking resistor, and remove the dummy plug.

For frame sizes FSF and FSG, you must breakout the openings from the connection cover for the power connections. Use side cutters or a fine saw blade.

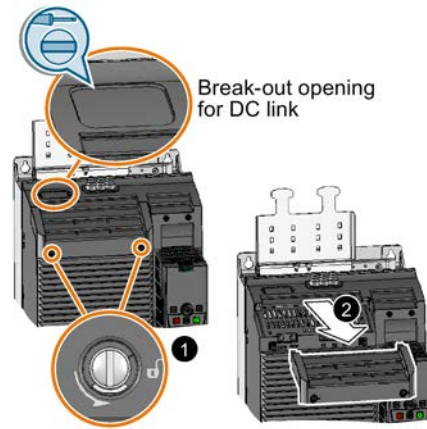

FSD ... FSG: Remove the top covers

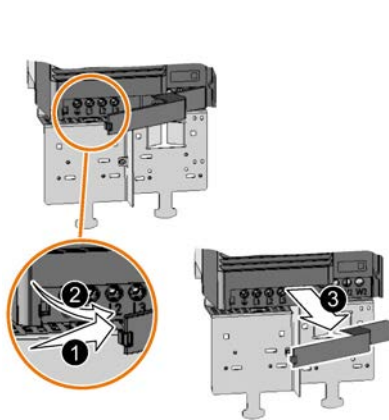

FSD, FSE: Remove the lower cover

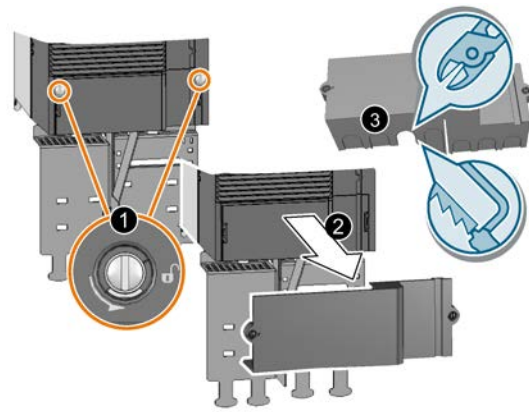

FSF, FSG: Remove the lower cover

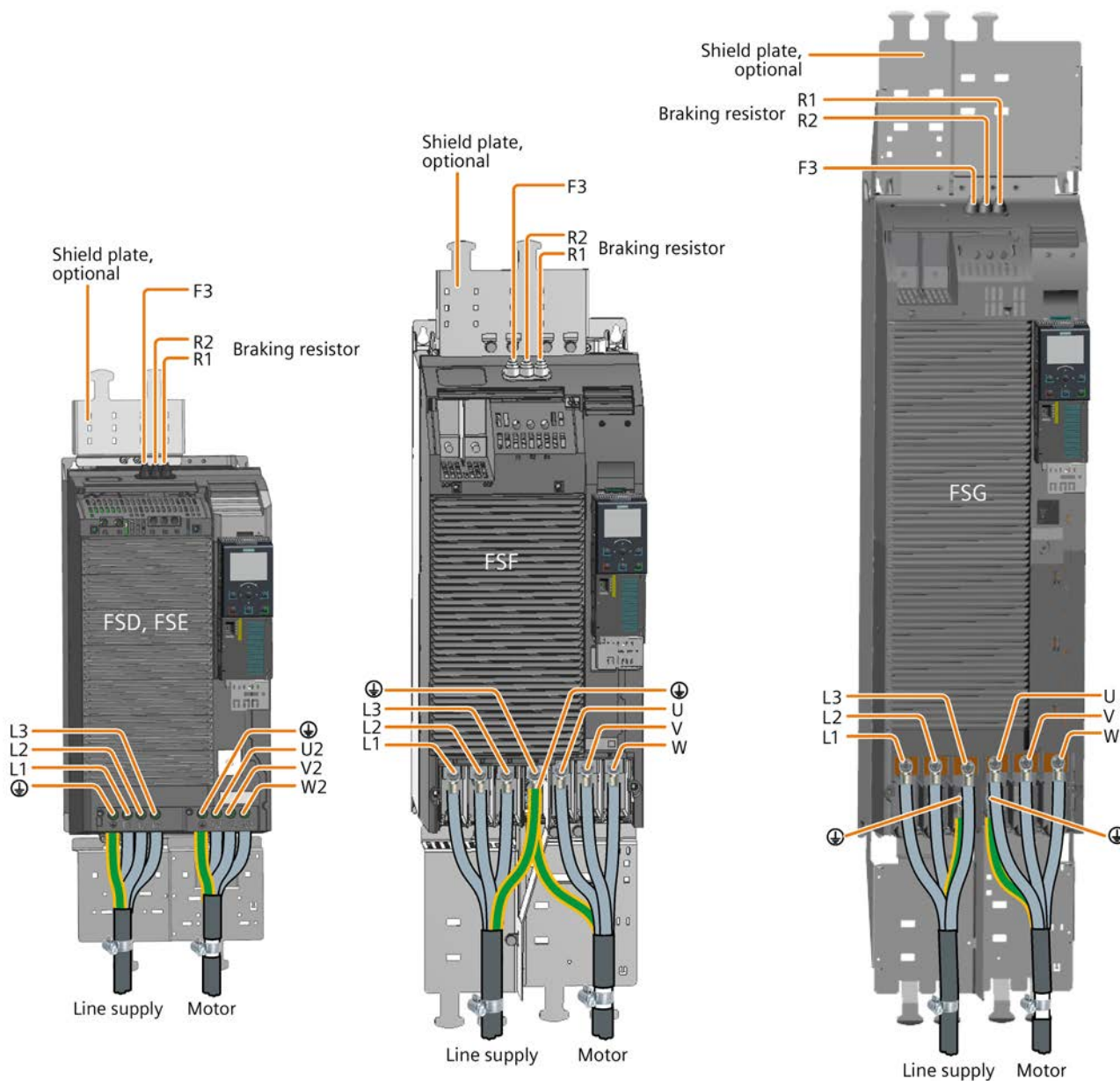

Figure 4-8 Connections for the line supply, motor and braking resistor

You must re-attach the connection covers in order to re-establish the touch protection of the converter after it has been connected up.

Additional information when connecting FSG converters

Note

Conductor cross-section 240 mm²

Cable lugs for M10 bolts according to SN71322 are suitable for cables with cross-sections of 35 mm² ... 185 mm² (1 AWG ... 2 × 350 MCM).

If you wish to establish connections with cables of 240 mm² (500 MCM), you must use narrow cable lugs, e.g. Klauke 12SG10. Other cable lugs are not suitable due to the narrow design of the converter.

The maximum permissible width of the cable lugs is 37 mm (1.45 inches).

Remove the plastic insulating plate as shown below to gain better access to the terminals for the power connections.

⚠ WARNING

Damage to converter as a result of operation without insulating plates

Without the insulating plates, voltage flashovers may occur between the phases.

- Replace the insulating plates after connecting the cables.

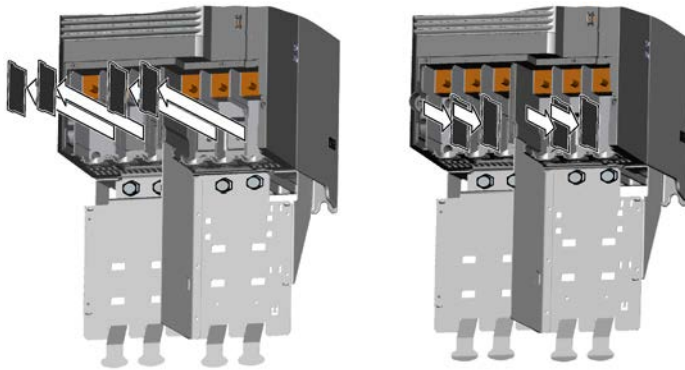

Braking resistor connection

Use the rubber cable gland as shown in the right-hand figure for connecting the braking resistor.

Using a sharp knife, cut the cap of the cable gland corresponding to the diameter of the connection cable of the braking resistor and establish the connections.

Connect the braking resistor at the R1 and R2 terminals.

An optional shield plate is available as strain relief for the connection cable of the braking resistor.

 Top shield plate - FSD ... FSG (Page 117)

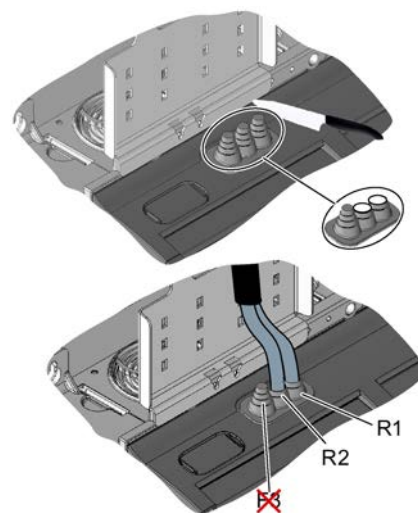

4.3 STO via Power Module terminals

Description

The "Safe Torque Off" (STO) safety function can be implemented via terminals on the power modules of frame sizes FSD ... FSG.

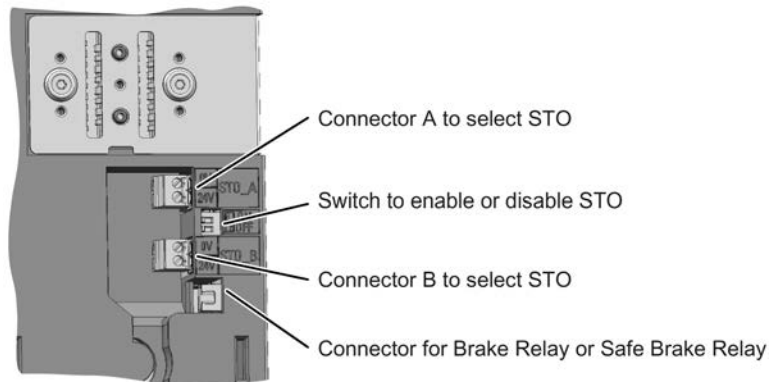

Figure 4-9 Terminals and switches for the "STO via power module terminals" function

The two switches have the following function:

- Both switches = ON: STO is enabled
- Both switches = OFF: STO is locked
- Two switches different: not permissible

Terminals STO_A and STO_B are low active.

Connect line to select STO

Use a SELV or PELV power supply with 24 V DC (20.4 V ... 28.8 V, maximum 60 V briefly) for the STO_A and STO_B connections.

Use a shielded cable with the following properties:

- Length ≤ 30 m
- Cross section $0.5 \text{ mm}^2 \dots + 1.5 \text{ mm}^2$ (20 ... 16 AWG)
- Insulated for 600 V

Use conductor end sleeves, stripped length 7 mm.

Procedure

1. Connect the cable to select STO at terminals STO_A and STO_B on the front of the power module.
2. Tighten the screws of the terminals with a torque of 0.2 Nm (2 lbf in).
3. Attach the shield to the shield plate of the Control Unit through the largest possible surface area.

You have connected the STO terminals.



Note**Configuring a safety function**

In order to use the "STO via power module terminals" safety function, the function has to be configured with a commissioning tool.

Further information and wiring examples are to be found in the "Safety Integrated" Function Manual.



Manuals for your converter (Page 167)

4.4 Connecting the motor to the converter in a star or delta connection

Overview

Standard induction motors up to a rated power of approximately 3 kW are usually connected in star/delta connection (Y/ Δ) at 400 V/230 V. For a 400-V line supply, you can connect the motor to the converter either in a star or in a delta connection.

Function description

Operating the motor in a star connection

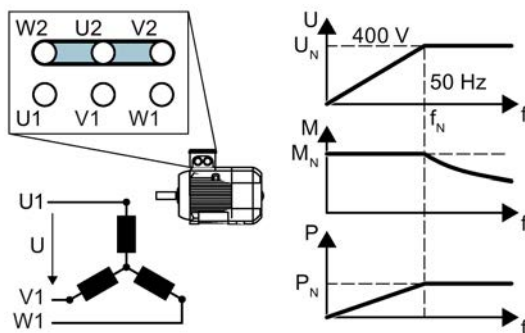

In a star connection, the motor can provide its rated torque M_N in the range 0 ... rated frequency f_N .

Rated voltage $U_N = 400$ V is available at a rated frequency $f_N = 50$ Hz.

The motor goes into field weakening above the rated frequency. In field weakening, the available motor torque decreases proportionally with $1/f$. In field weakening, the available power remains constant.

Operating the motor in a delta connection with 87 Hz characteristic

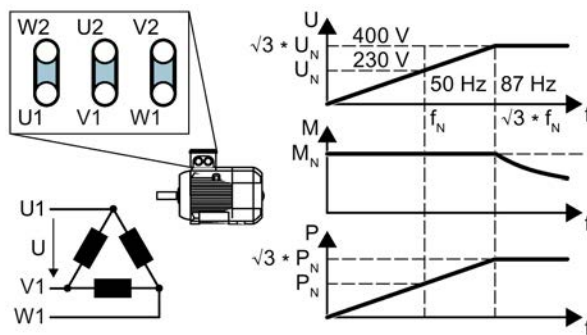

In a delta connection, the motor is operated with a voltage and frequency above its rated values. As a consequence, the motor power is increased by a factor $\sqrt{3} \approx 1.73$.

In the range $f = 0 \dots 87$ Hz, the motor can output its rated torque M_N .

The maximum voltage $U = 400$ V is available at a frequency of $f = \sqrt{3} \times 50$ Hz ≈ 87 Hz.



The motor only goes into field weakening above 87 Hz.

The higher motor power when operated with an 87 Hz characteristic has the following disadvantages:

- The converter must supply approximately 1.73x current. Select a converter based on its rated current - and not its rated power.
- The motor temperature increases more significantly than when operated with $f \leq 50$ Hz.
- The motor must have windings that are approved for a voltage > rated voltage U_N .
- As the fan impeller rotates faster, the motor has a higher noise level than operation with $f \leq 50$ Hz.

Further information

You can find more information on the Internet:

-  Operating motors at higher frequencies
(<https://support.industry.siemens.com/cs/ww/en/view/25338130>)
-  Parameterizing the 87 Hz characteristic
(<https://support.industry.siemens.com/cs/ww/en/view/88963613>)

Service and maintenance

WARNING

Fire or electric shock due to defective components

If an overcurrent protection device is triggered, the converter may be defective. A defective converter can cause a fire or electric shock.

- Have the converter and the overcurrent protection device checked by a specialist.

Repair

WARNING

Fire or electric shock due to improper repair

Improper repair of the converter may cause malfunctions or result in consequential damage such as fire or electric shock.

- Only commission the following persons to repair the converter:
 - Siemens customer service
 - A repair center that has been authorized by Siemens
 - Specialist personnel who are thoroughly acquainted with all the warnings and operating procedures contained in this manual.
- Only use original spare parts when carrying out repairs.

Recycling and disposal



For environmentally-friendly recycling and disposal of your old device, please contact a company certified for the disposal of waste electrical and electronic equipment, and dispose of the old device as prescribed in the respective country of use.

5.1 Maintenance

The purpose of maintenance is to maintain the specified condition of the Power Module.

Regularly remove dirt and pollution, and replace the fan in plenty of time.  Replacing a fan (Page 68)

Cleaning

Clean the converter with an anti-static brush, a vacuum cleaner and areas that are difficult to access, using dry compressed air (max. 1 bar).

Ventilation

The devices must be installed in a cabinet. Ensure that the cabinet's ventilation slots are not blocked. Check that the fan is functioning correctly.

Cables and screw terminals

Regularly check the cables for damage, and immediately replace any defective parts.

Regularly check that the screw terminals have been correctly tightened. Retighten the screws if necessary.

Note

The actual maintenance intervals depend on the installation and operating conditions.

Siemens offers its customers support in the form of service contracts. For further information, contact your Siemens regional office or sales office via the link below:



Siemens contact database (https://mall.industry.siemens.com/aspa_app?lang=en).

5.2 Installation after a long storage time

Overview

To avoid extra duties, Siemens recommends to run the converter for an hour with 100% main supply voltage once a year. If the converter has not been in operation for too long, you must form the DC link capacitors before switching the full mains voltage to the converter.

Precondition

Form the DC-link capacitors in the following cases:

- The converter was not operational for longer than one year.
- The date of manufacture of the converter was more than one year ago when installing the converter for the first time.

The date of manufacture of the converter is coded in positions 3 - 6 of the serial number.

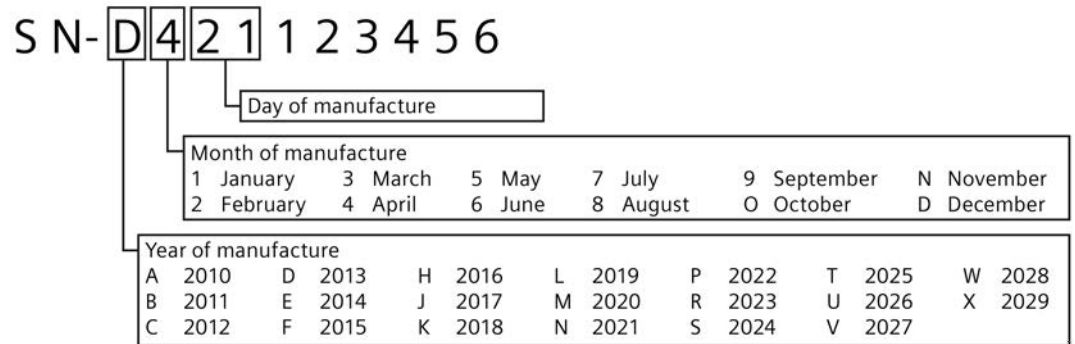

Figure 5-1 Data of manufacture in the serial number (example, April 21, 2013)

Description

You form the DC-link capacitors by connecting power to the converter as shown below.

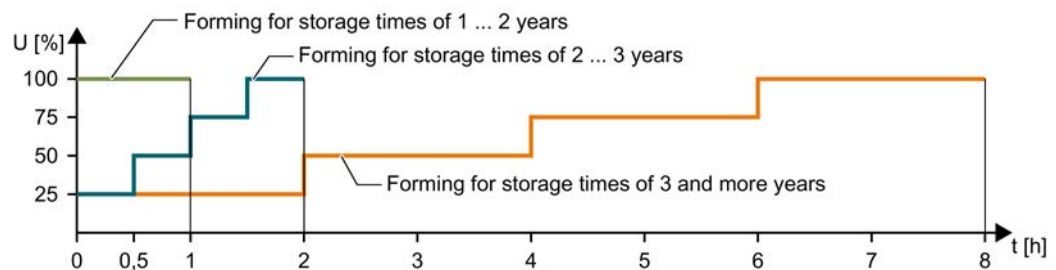

Figure 5-2 Forming the DC-link capacitors

5.3 Replacing a fan

Service life of the fan

The average service life of the fan is 40,000 hours. In practice, however, the service life may deviate from this value. Especially a dusty environment can block up the fan.

The fan must be replaced in good time to ensure that the converter is ready for operation.

Applies to all frame sizes

Proceed as follows to remove the fan unit:

Switch off the converter power supply before replacing the fan.



! WARNING

Electric shock as a result of a residual charge in power components

After the power supply has been switched off, it takes up to 5 minutes until the capacitors in the converter have discharged so that the residual charge is at a non-hazardous level.

- Check the voltage at the converter connections before you carry out any installation work.

5.3.1 Fan replacement FSA ... FSC

The fan module is installed at the bottom. It has one fan each for frame sizes FSA and FSB, and two for frame size C.

Procedure

1. Withdraw the line and motor cable plug connectors and, if available, remove the braking resistor from the Power Module.
2. Remove the shield plate from the Power Module.
3. Remove the fan module from the Power Module in steps ① and ② as shown in the diagram. Use a screwdriver if necessary.

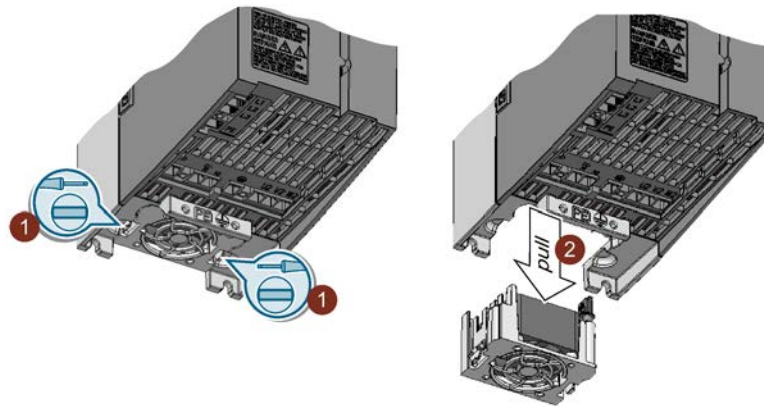

4. Install the new fan module in the inverse sequence.

You have replaced the fan module.



5.3.2 Fan replacement FSD ... FSF

The fan module is installed at the top.

Procedure

1. Remove the fan module from the Power Module in steps ① and ② as shown in the diagram. Use a screwdriver if necessary.

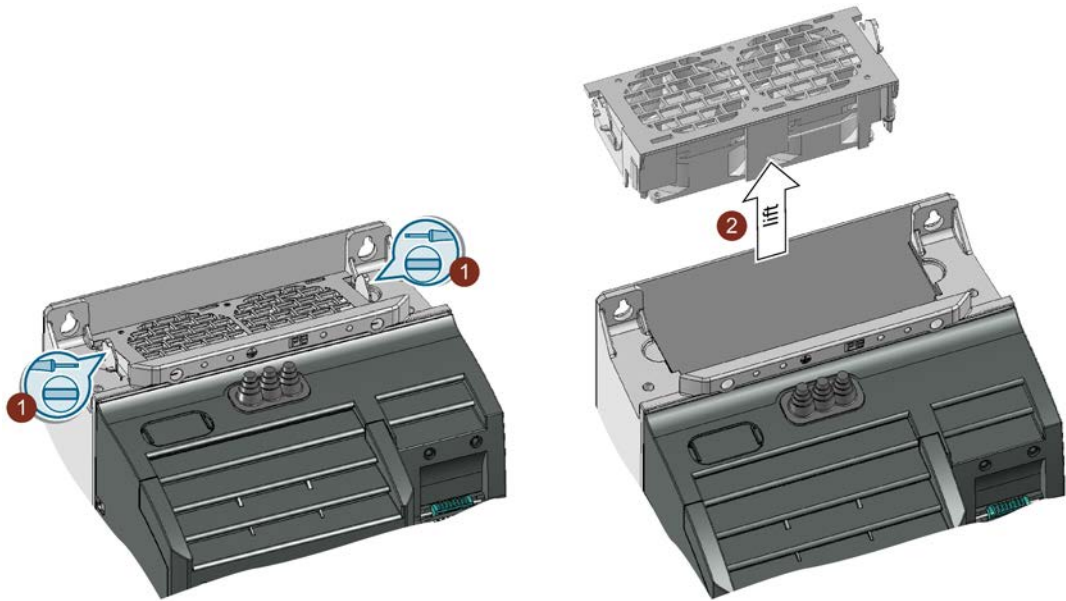

2. Install the new fan module in inverse sequence. By inserting the fan module, you establish the electrical connection between the converter and fan module.

You have replaced the fan module.

□

5.3.3 FSG fan replacement

The fan module is installed at the top.

Procedure

1. Remove the fan module from the Power Module in steps ① and ② as shown in the diagram. Use a screwdriver.

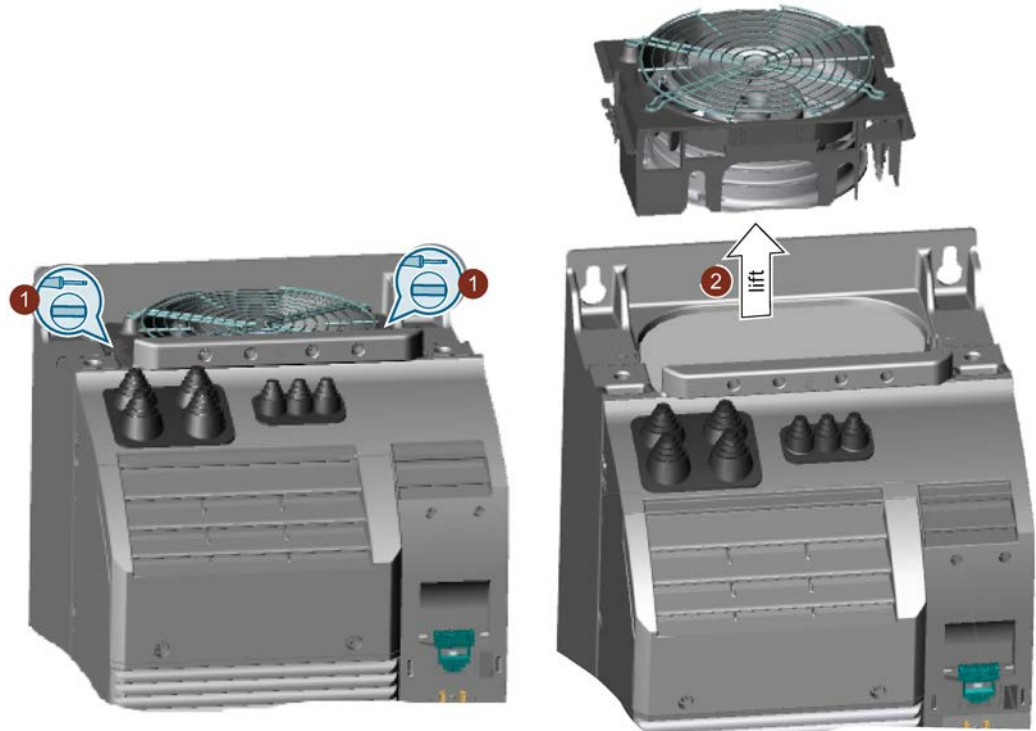

2. Install the new fan module in inverse sequence. By inserting the fan module, you establish the electrical connection between the converter and fan module.

You have replaced the fan module.



Further information

For more information about the article numbers for different fan kits, see Chapter "Spare parts (Page 115)".

Further information about the fan is provided on the Internet:

-  Fan behavior (<https://support.industry.siemens.com/cs/ww/en/view/109744237>)
-  Spares on Web (<https://www.automation.siemens.com/sow>)

Technical data

Power loss of the Power Modules

Note

Power loss for the FSA ... FSC Power Modules

The values specified for the power loss are typical values at 100% of the rated speed and 100% of the load corresponding to Low Overload.

Power loss for the FSD ... FSG Power Modules

The values specified for the power loss are typical values at 90% of the rated speed and 100% of the load corresponding to Low Overload.

Protective devices for the Power Module

The fuses listed in the following tables are examples of suitable fuses.

Additional components for branch protection are available in the Internet:

 Branch protection and short-circuit strength according to UL and IEC (<https://support.industry.siemens.com/cs/ww/en/view/109801083>)

Number of starting operations for converter

The frequency of operation for the converter is every 120 s.

The number of starting operations states how often line voltage may be switched to the de-energized converter.

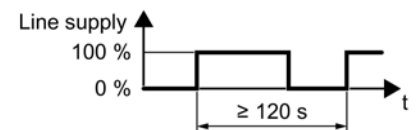

6.1 Electromagnetic compatibility - Overview

Electromagnetic compatibility according to EN61800-3



Property	Version
Interference immunity	The converters are suitable for use in the first and second industrial environments
Interference emission - second environment	Category C2 for converters with integrated radio interference suppression filter
	Category C2 for converters without filter with optional external radio interference suppression filter for grounded line supplies (recommended for operation in conjunction with a residual current protective device RCD)
	Category C3 for 690-V converters with integrated radio interference suppression filter, frame size FSF, FSG
	Category C4 for converters without integrated radio interference suppression filter for operation on IT line supplies

Additional information as well as conditions for using the converter in the first environment are provided in the following Section:



Electromagnetic compatibility of variable-speed drives (Page 107).

6.2 Ambient conditions

Property	Version
Ambient conditions for transport in the transport packaging	
Air-conditioning	- 40 °C ... + 70 °C, according to Class 2K4 to EN 60721-3-2:1997 maximum humidity 95% at 40 °C
Mechanical system	Shocks and vibrations permissible according to 2M3 to IEC 60721-3-2:1997
Chemical substances	Protected according to Class 2C2 to IEC 60721-3-2:1997
Biological ambient conditions	Suitable according to Class 2B1 to IEC 60721-3-2:1997
Ambient conditions for long-term storage in the transport packaging	
Air-conditioning	- 25 °C ... + 55 °C, according to Class 1K4 to IEC 60721-3-1:1997
Chemical substances	Protected according to Class 1C2 to IEC 60721-3-1:1997
Biological ambient conditions	Suitable according to Class 1B1 to IEC 60721-3-1:1997
Ambient conditions in operation	
Installation altitude	Up to 1000 m above sea level without limitations  Restrictions for special ambient conditions (Page 103)
Air-conditioning ¹⁾	<ul style="list-style-type: none"> • FSA ... FSC ambient operating temperature ²⁾ <ul style="list-style-type: none"> – For operation according to Low Overload: -10 °C ... +40 °C – For operation according to High Overload: -10 °C ... +50 °C –  Restrictions for special ambient conditions (Page 103) • FSD ... FSG ambient operating temperature ²⁾ <ul style="list-style-type: none"> – For operation according to Low Overload: -20 °C ... +40 °C – For operation according to High Overload: -20 °C ... +50 °C –  Restrictions for special ambient conditions (Page 103) • Relative humidity: 5 ... 95%, condensation not permitted • Oil mist, ice formation, condensation, dripping water, spraying water, splashing water and water jets are not permitted
Mechanical system	Vibration test during operation according to IEC 60068-2-6 Test Fc (sinusoidal) <ul style="list-style-type: none"> • 0 ... 57 Hz: 0.075 mm deflection amplitude • 57 ... 150 Hz: 1 g acceleration amplitude • 10 frequency cycles per axis Shock test according to IEC 60068-2-27 Test Ea (half-sine) <ul style="list-style-type: none"> • 5 g peak acceleration • 30 ms duration • 3 shocks in all three axes in both directions
Chemical substances	Protected according to 3C2 to IEC 60721-3-3:2002
Biological ambient conditions	Suitable according to 3B1 to IEC 60721-3-3: 2002
Pollution	Suitable for environments with degree of pollution 2 according to EN 61800-5-1
Cooling	Forced air cooling AF, according to EN 60146
Cooling air	Clean and dry air
Noise emission	Maximum 75 db(A)

¹⁾ Increased ruggedness regarding temperature range and relative humidity; therefore better than 3K3 according to IEC 60721-3-3: 2002

²⁾ Observe the permissible ambient operating temperatures for the Control Unit and the Operator Panel (IOP-2 or BOP-2).

6.3 Overload capability of the converter

Overload capability is the property of the converter to temporarily supply a current that is higher than the rated current to accelerate a load. Two typical load cycles are defined to clearly demonstrate the overload capability: "Low Overload" and "High Overload"

Definitions

Base load

Constant load between the accelerating phases of the drive

Low Overload

- **LO base load input current**
Permissible input current for a "Low Overload" load cycle
- **LO base load output current**
Permissible output current for a "Low Overload" load cycle
- **LO base load power**
Rated power based on the LO base load output current

High Overload

- **HO base load input current**
Permissible input current for a "High Overload" load cycle
- **HO base load output current**
Permissible output current for a "High Overload" load cycle
- **HO base load power**
Rated power based on the HO base load output current

If not specified otherwise, the power and current data in the technical data always refer to a load cycle according to Low Overload.

We recommend using the "SIZER" engineering software to select the converter.

You can find additional information about SIZER on the Internet:



Download Sizer

<http://support.automation.siemens.com/WW/view/en/10804987/130000>

Load cycles and typical applications:

"Low Overload" load cycle

The "Low Overload" load cycle assumes a uniform base load with low requirements placed on brief accelerating phases. Typical applications when designing according to "Low Overload" include:

- Pumps, fans and compressors
- Wet or dry blasting technology
- Mills, mixers, kneaders, crushers, agitators
- Basic spindles
- Rotary furnaces
- Extruders

"High Overload" load cycle

The "High Overload" load cycle permits dynamic accelerating phases at a reduced base load. Typical applications when designing according to "High Overload" include:

- Horizontal and vertical conveyor technology (conveyor belts, roller conveyors, chain conveyors)
- Centrifuges
- Escalators/moving stairways
- Lifters/Lowerers
- Elevators
- Gantry cranes
- Cable railways
- Storage and retrieval machines

Typical converter load cycles

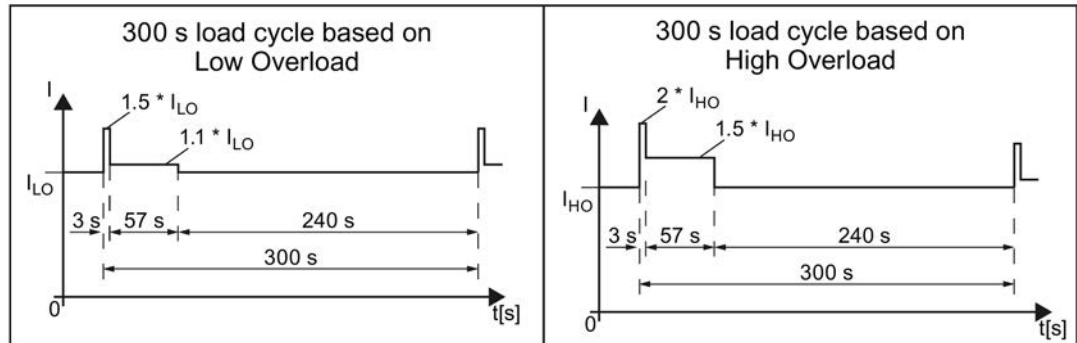

Figure 6-1 "Low Overload" and "High Overload" load cycles

The PM240-2 is designed to have a service life of 10 years under the following conditions:

- Nominal load at 40 °C: 4000 h/y
- Idle time or standby at 20 °C: 4000 h/y
- Power off: 760 h/y

Under nominal operating conditions (for example, nominal ambient temperatures), the PM240-2 Power Module is rated for operation under nominal load or the specified HO/LO overload cycles. Any deviation from the rated load conditions will have an influence on the service life of the Power Module.

Under the following load circumstances, the Power Module will have a reduced service life due to excessive temperature rise of the integrated power semiconductors:

- Large current fluctuations
- Long short-circuit or overload duration
- Frequent occurrences of overload

To extend the service life of the Power Module, Siemens recommends you to take the following measures:

- Lower the rated load
- Reduce the maximum current
- Reduce the occurrences of overload
- Reduce the occurrences of energizing the converter that starts with the empty DC link; use an input signal to start or stop the converter

6.4 Data regarding the power loss in partial load operation

You can find data regarding power loss in partial load operation on the Internet:



Partial load operation (<https://support.industry.siemens.com/cs/ww/en/view/94059311>)

6.5 200 V converters

Motors for 200 V Power Modules

For the 200 V Power Modules, induction motors are permissible in the range from 25% ... 150% of the converter power without any restrictions.





Permissible motors

Note

Motors for converter operation

Only use motors that are suitable for operation with converters with a DC link.

6.5.1 General data, 200 V converters

Property	Version		
Line voltage	FSA ... FSC	200 V ... 240 V 1 AC ± 10%	0.55 kW ... 4 kW - LO 0.37 kW ... 3 kW - HO
		200 V ... 240 V 3 AC ± 10%	0.55 kW ... 7.5 kW - LO 0.37 kW ... 5.5 kW - HO
	FSD ... FSF	200 V ... 240 V 3 AC ± 10%	11 kW ... 55 kW - LO
		(in operation -20% < 1 min)	7.5 kW ... 45 kW - HO
Line supply configurations	Grounded TN/TT line supplies or non-grounded IT line supplies  Permissible line supplies (Page 44)		
Line impedance	FSA ... FSC	2% ≤ Uk < 4%. For Uk < 2%, we recommend a line reactor, or a Power Module with the next higher power rating.	
	FSD ... FSF	No restrictions	
Power factor λ	FSA ... FSC	0.7 without line reactor for Uk ≥ 2% 0.85 with line reactor for Uk < 2%	
	FSD ... FSF	> 0.9	
Output voltage	0 V 3 AC ... 0.95 × input voltage		
Input frequency	50 Hz ... 60 Hz, ± 3 Hz		
Output frequency	0 ... 550 Hz, depending on the control mode		
Inrush current	< LO base load input current		
Overvoltage category according to EN 61800-5-1	III for line supplies		
Pulse frequency	4 kHz (factory setting), Adjustable in steps of 2 kHz.		
	 Current reduction as a function of the pulse frequency (Page 84)		
	If you increase the pulse frequency, the converter reduces the maximum output current.		
Short-circuit current (SCCR) and branch protection	Maximum permissible line short-circuit current ≤ 100 kA rms  Branch protection and short-circuit strength according to UL and IEC (https://support.industry.siemens.com/cs/ww/en/view/109801083)		
Degree of protection according to EN 60529	IP20		
Protection class according to EN 61800-5-1	The converters are devices with protection class I		
Touch protection according to EN 50274	DGUV regulation 3 when used for the intended purpose		
Cooling in compliance with EN 60146	Forced air cooling AF		
Safety Integrated	See function manual "Safety Integrated"		
	 "Safety Integrated" function manual (https://support.industry.siemens.com/cs/ww/en/view/109751320)		

Dependency of input voltage and output power

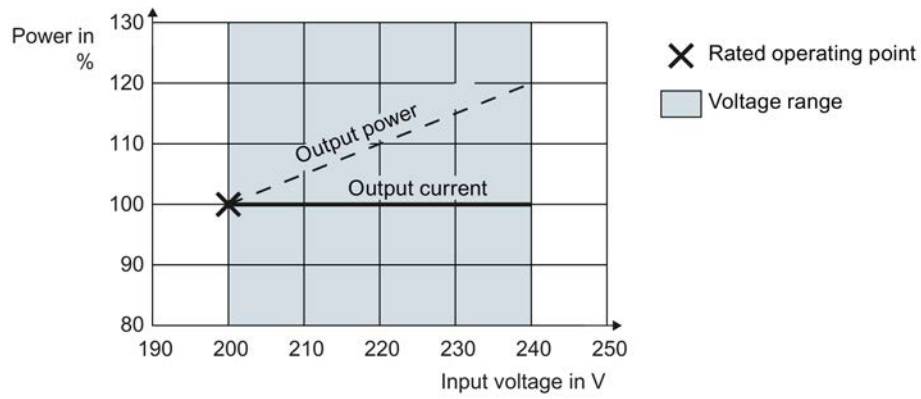

6.5.2 Specific technical data, 200 V converters

Table 6- 1 PM240-2, IP20, frame size A, 200 V ... 240 V 1 AC / 3 AC

Article No. without filter	6SL3210-1PB13-0ULO	6SL3210-1PB13-8ULO
Article No. with filter	6SL3210-1PB13-0ALO	6SL3210-1PB13-8ALO
LO base load power	0.55 kW	0.75 kW
1 AC LO base load input current	7.5 A	9.6 A
3 AC LO base load input current	4.2 A	5.5 A
LO base load output current	3.2 A	4.2 A
HO base load power	0.37 kW	0.55 kW
1 AC HO base load input current	6.6 A	8.4 A
3 AC HO base load input current	3.0 A	4.2 A
HO base load output current	2.3 A	3.2 A
Fuse according to IEC	3NA3805 (16 A)	3NA3805 (16 A)
Fuse according to UL, class J	15 A	15 A
Power loss	0.04 kW	0.04 kW
Required cooling air flow	5 l/s	5 l/s
Weight without filter	1.4 kg	1.4 kg
Weight with filter	1.6 kg	1.6 kg

Table 6- 2 PM240-2, IP20, frame size B, 200 V ... 240 V 1 AC / 3 AC

Article No. without filter	6SL3210-1PB15-5ULO	6SL3210-1PB17-4ULO	6SL3210-1PB21-0ULO
Article No. with filter	6SL3210-1PB15-5ALO	6SL3210-1PB17-4ALO	6SL3210-1PB21-0ALO
LO base load power	1.1 kW	1.5 kW	2.2 kW
1 AC LO base load input current	13.5 A	18.1 A	24.0 A
3 AC LO base load input current	7.8 A	9.7 A	13.6 A
LO base load output current	6 A	7.4 A	10.4 A
HO base load power	0.75 kW	1.1 kW	1.5 kW
1 AC HO base load input current	11.8 A	15.8 A	20.9 A
3 AC HO base load input current	5.5 A	7.8 A	9.7 A
HO base load output current	4.2 A	6 A	7.4 A
Fuse according to IEC	3NA3812 (32 A)	3NA3812 (32 A)	3NA3812 (32 A)
Fuse according to UL, class J	35 A	35 A	35 A
Power loss	0.05 kW	0.07 kW	0.12 kW
Required cooling air flow	9.2 l/s	9.2 l/s	9.2 l/s
Weight without filter	2.8 kg	2.8 kg	2.8 kg
Weight with filter	3.1 kg	3.1 kg	3.1 kg

Technical data

6.5 200 V converters

Table 6- 3 PM240-2, IP 20, frame size C, 200 V ... 240 V 1 AC / 3 AC

Article No. without filter	6SL3210-1PB21-4UL0	6SL3210-1PB21-8UL0
Article No. with filter	6SL3210-1PB21-4AL0	6SL3210-1PB21-8AL0
LO base load power	3 kW	4 kW
1 AC LO base load input current	35.9 A	43.0 A
3 AC LO base load input current	17.7 A	22.8 A
LO base load output current	13.6 A	17.5 A
HO base load power	2.2 kW	3 kW
1 AC HO base load input current	31.3 A	37.5 A
3 AC HO base load input current	13.6 A	17.7 A
HO base load output current	10.4 A	13.6 A
Fuse according to IEC	3NA3820 (50 A)	3NA3820 (50 A)
Fuse according to UL, class J	50 A	50 A
Power loss	0.14 kW	0.18 kW
Required cooling air flow	18.5 l/s	18.5 l/s
Weight without filter	5.0 kg	5.0 kg
Weight with filter	5.2 kg	5.2 kg

Table 6- 4 PM240-2, IP 20, frame size C, 200 V ... 240 V 3 AC

Article No. without filter	6SL3210-1PC22-2UL0	6SL3210-1PC22-8UL0
Article No. with filter	6SL3210-1PC22-2AL0	6SL3210-1PC22-8AL0
LO base load power	5.5 kW	7.5 kW
LO base load input current	28.6 A	36.4 A
LO base load output current	22.0 A	28.0 A
HO base load power	4 kW	5.5 kW
HO base load input current	22.8 A	28.6 A
HO base load output current	17.5 A	22.0 A
Fuse according to IEC	3NA3820 (50 A)	3NA3820 (50 A)
Fuse according to UL, class J	50 A	50 A
Power loss	0.2 kW	0.26 kW
Required cooling air flow	18.5 l/s	18.5 l/s
Weight without filter	5.0 kg	5.0 kg
Weight with filter	5.2 kg	5.2 kg

Table 6- 5 PM240-2, IP20, frame size D, 200 V ... 240 V 3 AC

Article No. without filter	6SL3210-1PC24-2UL0	6SL3210-1PC25-4UL0	6SL3210-1PC26-8UL0
LO base load power	11 kW	15 kW	18.5 kW
LO base load input current	40 A	51 A	64 A
LO base load output current	42 A	54 A	68 A
HO base load power	7.5 kW	11 kW	15 kW
HO base load input current	36 A	43 A	56 A
HO base load output current	35 A	42 A	54 A
Fuse according to IEC	3NA3822 (63 A)	3NA3824 (80 A)	3NA3830 (100 A)
Fuse according to UL, class J	60 A	70 A	90 A
Power loss	0.45 kW	0.61 kW	0.82 kW
Required cooling air flow	55 l/s	55 l/s	55 l/s
Weight	18.3 kg	18.3 kg	18.3 kg

Table 6- 6 PM240-2, IP20, frame size E, 200 V ... 240 V 3 AC

Article No. without filter	6SL3210-1PC28-0UL0	6SL3210-1PC31-1UL0
LO base load power	22 kW	30 kW
LO base load input current	76 A	98 A
LO base load output current	80 A	104 A
HO base load power	18.5 kW	22 kW
HO base load input current	71 A	83 A
HO base load output current	68 A	80 A
Fuse according to IEC	3NA3830 (100 A)	3NA3836 (160 A)
Fuse according to UL, class J	100 A	150 A
Power loss	0.92 kW	1.28 kW
Required cooling air flow	83 l/s	83 l/s
Weight	26.8 kg	26.8 kg

Table 6- 7 PM240-2, IP20, frame size F, 200 V ... 240 V 3 AC

Article No. without filter	6SL3210-1PC31-3UL0	6SL3210-1PC31-6UL0	6SL3210-1PC31-8UL0
LO base load power	37 kW	45 kW	55 kW
LO base load input current	126 A	149 A	172 A
LO base load output current	130 A	154 A	178 A
HO base load power	30 kW	37 kW	45 kW
HO base load input current	110 A	138 A	164 A
HO base load output current	104 A	130 A	154 A
Fuse according to IEC	3NA3140 (200 A)	3NA3140 (200 A)	3NA3142 (224 A)
Fuse according to UL, class J	175 A	200 A	250 A
Power loss	1.38 kW	1.72 kW	2.09 kW
Required cooling air flow	153 l/s	153 l/s	153 l/s
Weight	58 kg	58 kg	58 kg

6.5.3 Current derating depending on the pulse frequency, 200 V converters

LO base load

Article number	LO power [kW]	Pulse frequency [kHz]							
		2	4 *)	6	8	10	12	14	16
		LO base load output current [A]							
6SL3210-1PB13-0 . LO	0.55	3.2	3.2	2.7	2.2	1.9	1.6	1.4	1.3
6SL321 . -1PB13-8 . LO	0.75	4.2	4.2	3.6	2.9	2.5	2.1	1.9	1.7
6SL3210-1PB15-5 . LO	1.1	6	6	5.1	4.2	3.6	3	2.7	2.4
6SL3210-1PB17-4 . LO	1.5	7.4	7.4	6.3	5.2	4.4	3.7	3.3	3
6SL321 . -1PB21-0 . LO	2.2	10.4	10.4	8.8	7.3	6.2	5.2	4.7	4.2
6SL3210-1PB21-4 . LO	3	13.6	13.6	11.6	9.5	8.2	6.8	6.1	5.4
6SL321 . -1PB21-8 . LO	4	17.5	17.5	14.9	12.3	10.5	8.8	7.9	7
6SL3210-1PC22-2 . LO	5.5	22	22	18.7	15.4	13.2	11	9.9	8.8
6SL3210-1PC22-8 . LO	7.5	28	28	23.8	19.6	16.8	14	12.6	11.2
6SL3210-1PC24-2UL0	11	42	42	35.7	29.4	25.2	21	18.9	16.8
6SL3210-1PC25-4UL0	15	54	54	45.9	37.8	32.4	27	24.3	21.6
6SL321 . -1PC26-8UL0	18.5	68	68	57.8	47.6	40.8	34	30.6	27.2
6SL3210-1PC28-0UL0	22	80	80	68	56	48	40	36	32
6SL321 . -1PC31-1UL0	30	104	104	88.4	72.8	62.4	52	46.8	41.6
6SL3210-1PC31-3UL0	37	130	130	110.5	91	---	---	---	---
6SL3210-1PC31-6UL0	45	154	154	130.9	107.8	---	---	---	---
6SL321 . -1PC31-8UL0	55	178	178	151.3	124.6	---	---	---	---

*) Factory setting

The permissible motor cable length depends on the particular cable type and the pulse frequency that has been selected.

HO base load

Article number	HO power [kW]	Pulse frequency [kHz]							
		2	4 *)	6	8	10	12	14	16
		HO base load output current [A]							
6SL3210-1PB13-0 . LO	0.37	2.3	2.3	2	1.6	1.4	1.2	1	0.9
6SL321 . -1PB13-8 . LO	0.55	3.2	3.2	2.7	2.2	1.9	1.6	1.4	1.3
6SL3210-1PB15-5 . LO	0.75	4.2	4.2	3.6	2.9	2.5	2.1	1.9	1.7
6SL3210-1PB17-4 . LO	1.1	6	6	5.1	4.2	3.6	3	2.7	2.4
6SL321 . -1PB21-0 . LO	1.5	7.4	7.4	6.3	5.2	4.4	3.7	3.3	3
6SL3210-1PB21-4 . LO	2.2	10.4	10.4	8.8	7.3	6.2	5.2	4.7	4.2
6SL321 . -1PB21-8 . LO	3	13.6	13.6	11.6	9.5	8.2	6.8	6.1	5.4
6SL321 .-1PC22-2 . LO	4	17.5	17.5	14.9	12.3	10.5	8.8	7.9	7
6SL321 .-1PC22-8 . LO	5.5	22	22	18.7	15.4	13.2	11	9.9	8.8
6SL3210-1PC24-2UL0	7.5	35	35	23.8	19.6	16.8	14	12.6	11.2
6SL3210-1PC25-4UL0	11	42	42	35.7	29.4	25.2	21	18.9	16.8
6SL321 . -1PC26-8UL0	15	54	54	45.9	37.8	32.4	27	24.3	21.6
6SL3210-1PC28-0UL0	18.5	68	68	57.8	47.6	40.8	34	30.6	27.2
6SL321 . -1PC31-1UL0	22	80	80	68	56	48	40	36	32
6SL3210-1PC31-3UL0	30	104	104	88.4	72.8	62.4	52	46.8	41.6
6SL3210-1PC31-6UL0	37	130	130	110.5	91	---	---	---	---
6SL321 . -1PC31-8UL0	45	154	154	130.9	107.8	---	---	---	---

*) Factory setting

The permissible motor cable length depends on the particular cable type and the pulse frequency that has been selected.

6.6 400 V converters

Motors for 400 V Power Modules

For the 400 V Power Modules, induction motors are permissible in the range from 25 % ... 150 % of the converter power without any restrictions.





Permissible motors

Note

Motors for converter operation

Only use motors that are suitable for operation with converters with a DC link.

6.6.1 General data, 400 V converters

Property	Version
Line voltage	FSA ... FSC 380 V ... 480 V 3 AC \pm 10%
	FSD ... FSG 380 V (-20 %) ... 480 V 3 AC + 10%
Line supply configurations	Grounded TN/TT line supplies or non-grounded IT line supplies  Permissible line supplies (Page 44)
Line impedance	FSA ... FSC 1% \leq Uk < 4%, for values smaller than 1%, we recommend a line reactor, or a Power Module with the next higher power rating.
	FSD ... FSG No restrictions
Power factor λ	FSA ... FSC 0.7 without line reactor for Uk \geq 1% 0.85 with line reactor for Uk < 1%
	FSD ... FSG > 0.9
Output voltage	0 V 3 AC ... 0.95 x input voltage (max.)
Input frequency	50 Hz ... 60 Hz, \pm 3 Hz
Output frequency	0 ... 550 Hz, depending on the control mode
Inrush current	< LO base load input current
Overvoltage category according to EN 61800-5-1	III for line supplies
Pulse frequency	Factory setting
	<ul style="list-style-type: none"> • 4 kHz for devices with an LO base load power < 110 kW • 2 kHz for devices with an LO base load power \geq 110 kW Can be adjusted in 2 kHz steps as follows: <ul style="list-style-type: none"> • 2 kHz ... 16 kHz for devices with an LO base load power < 55 kW • 2 kHz ... 8 kHz for devices with an LO base load output of 55 kW ... 250 kW If you increase the pulse frequency, the converter reduces the maximum output current.  Current reduction as a function of the pulse frequency (Page 93)
Short-circuit current (SCCR) and branch protection	Maximum permissible line short-circuit current \leq 100 kA rms
	 Branch protection and short-circuit strength according to UL and IEC https://support.industry.siemens.com/cs/ww/en/view/109801083
Braking methods	DC braking, compound braking, dynamic braking with integrated braking chopper
Degree of protection according to EN 60529	IP20
Protection class according to EN 61800-5-1	The converters are devices with protection class I
Touch protection according to EN 50274	DGUV regulation 3 when used for the intended purpose
Cooling in compliance with EN 60146	Forced air cooling AF
Safety Integrated	See function manual "Safety Integrated"
	 "Safety Integrated" function manual https://support.industry.siemens.com/cs/ww/en/view/109751320

Dependency of input voltage and output power

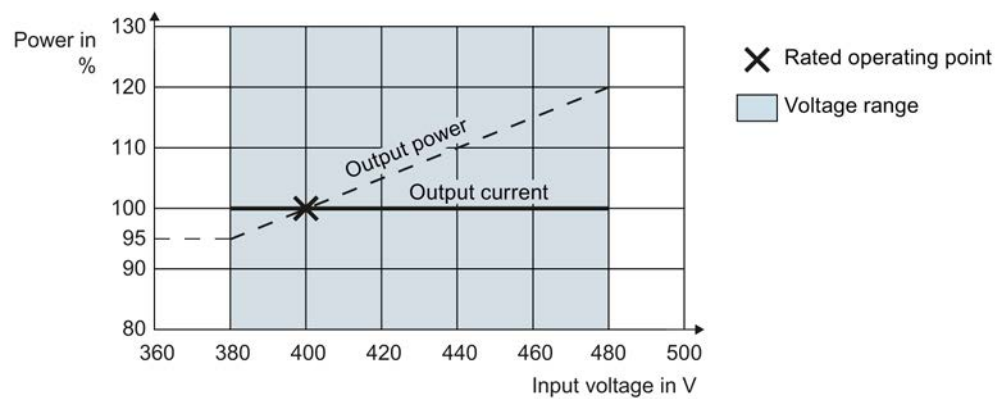

6.6.2 Specific technical data, 400 V converters

Table 6- 8 PM240-2, IP20, frame size A, 380 V ... 480 V 3 AC

Article No. without filter	6SL3210-1PE11-8UL1	6SL3210-1PE12-3UL1	6SL3210-1PE13-2UL1
Article No. with filter	6SL3210-1PE11-8AL1	6SL3210-1PE12-3AL1	6SL3210-1PE13-2AL1
LO base load power	0.55 kW	0.75 kW	1.1 kW
LO base load input current	2.3 A	2.9 A	4.1 A
LO base load output current	1.7 A	2.2 A	3.1 A
HO base load power	0.37 kW	0.55 kW	0.75 kW
HO base load input current	2.0 A	2.6 A	3.3 A
HO base load output current	1.3 A	1.7 A	2.2 A
Fuse according to IEC	3NA3803 (10 A)	3NA3803 (10 A)	3NA3805 (16 A)
Fuse according to UL, class J	10 A	10 A	15 A
Power loss	0.04 kW	0.04 kW	0.04 kW
Required cooling air flow	5 l/s	5 l/s	5 l/s
Weight without filter	1.3 kg	1.3 kg	1.3 kg
Weight with filter	1.5 kg	1.5 kg	1.5 kg

Table 6- 9 PM240-2, IP20, frame size A, 380 V ... 480 V 3 AC

Article No. without filter	6SL3210-1PE14-3UL1	6SL3210-1PE16-1UL1	6SL3210-1PE18-0UL1
Article No. with filter	6SL3210-1PE14-3AL1	6SL3210-1PE16-1AL1	6SL3210-1PE18-0AL1
LO base load power	1.5 kW	2.2 kW	3.0 kW
LO base load input current	5.5 A	7.7 A	10.1 A
LO base load output current	4.1 A	5.9 A	7.7 A
HO base load power	1.1 kW	1.5 kW	2.2 kW
HO base load input current	4.7 A	6.1 A	8.8 A
HO base load output current	3.1 A	4.1 A	5.9 A
Fuse according to IEC	3NA3805 (16 A)	3NA3805 (16 A)	3NA3805 (16 A)
Fuse according to UL, class J	15 A	15 A	15 A
Power loss	0.07 kW	0.1 kW	0.12 kW
Required cooling air flow	5 l/s	5 l/s	5 l/s
Weight without filter	1.4 kg	1.4 kg	1.4 kg
Weight with filter	1.6 kg	1.6 kg	1.6 kg

Table 6- 10 PM240-2, IP20, frame size B, 380 V ... 480 V 3 AC

Article No. without filter	6SL3210-1PE21-1ULO	6SL3210-1PE21-4ULO	6SL3210-1PE21-8ULO
Article No. with filter	6SL3210-1PE21-1ALO	6SL3210-1PE21-4ALO	6SL3210-1PE21-8ALO
LO base load power	4.0 kW	5.5 kW	7.5 kW
LO base load input current	13.3 A	17.2 A	22.2 A
LO base load output current	10.2 A	13.2 A	18.0 A
HO base load power	3.0 kW	4.0 kW	5.5 kW
HO base load input current	11.6 A	15.3 A	19.8 A
HO base load output current	7.7 A	10.2 A	13.2 A
Fuse according to IEC	3NA3812 (32 A)	3NA3812 (32 A)	3NA3812 (32 A)
Fuse according to UL, class J	35 A	35 A	35 A
Power loss	0.11 kW	0.15 kW	0.2 kW
Required cooling air flow	9.2 l/s	9.2 l/s	9.2 l/s
Weight without filter	2.9 kg	2.9 kg	3.0 kg
Weight with filter	3.1 kg	3.1 kg	3.2 kg

Table 6- 11 PM240-2, IP20, frame size C, 380 V ... 480 V 3 AC

Article No. without filter	6SL3210-1PE22-7ULO	6SL3210-1PE23-3ULO
Article No. with filter	6SL3210-1PE22-7ALO	6SL3210-1PE23-3ALO
LO base load power	11.0 kW	15.0 kW
LO base load input current	32.6 A	39.9 A
LO base load output current	26.0 A	32.0 A
HO base load power	7.5 kW	11.0 kW
HO base load input current	27.0 A	36.0 A
HO base load output current	18.0 A	26.0 A
Fuse according to IEC	3NA3820 (50 A)	3NA3820 (50 A)
Fuse according to UL, class J	50 A	50 A
Power loss	0.3 kW	0.37 kW
Required cooling air flow	18.5 l/s	18.5 l/s
Weight without filter	4.7 kg	4.8 kg
Weight with filter	5.3 kg	5.4 kg

6.6 400 V converters

Table 6- 12 PM240-2, IP20, frame size D, 380 V ... 480 V 3 AC

Article No. without filter	6SL3210-1PE23-8ULO	6SL3210-1PE24-5ULO	6SL3210-1PE26-0ULO
Article No. with filter	6SL3210-1PE23-8ALO	6SL3210-1PE24-5ALO	6SL3210-1PE26-0ALO
LO base load power	18.5 kW	22 kW	30 kW
LO base load input current	36 A	42 A	57 A
LO base load output current	38 A	45 A	60 A
HO base load power	15 kW	18.5 kW	22 kW
HO base load input current	33 A	38 A	47 A
HO base load output current	32 A	38 A	45 A
Fuse according to IEC	3NA3822 (63 A)	3NA3824 (80 A)	3NA3830 (100 A)
Fuse according to UL, class J	60 A	70 A	90 A
Power loss without filter	0.57 kW	0.70 kW	0.82 kW
Power loss with filter	0.58 kW	0.71 kW	0.83 kW
Required cooling air flow	55 l/s	55 l/s	55 l/s
Weight without filter	16.6 kg	15.55 kg	18.3 kg
Weight with filter	18.3 kg	17.25 kg	19 kg

Table 6- 13 PM240-2, IP20, frame size D, 380 V ... 480 V 3 AC

Article No. without filter	6SL3210-1PE27-5ULO
Article No. with filter	6SL3210-1PE27-5ALO
LO base load power	37 kW
LO base load input current	70 A
LO base load output current	75 A
HO base load power	30 kW
HO base load input current	62 A
HO base load output current	60 A
Fuse according to IEC	3NA3830 (100 A)
Fuse according to UL, class J	100 A
Power loss without filter	1.09 kW
Power loss with filter	1.10 kW
Required cooling air flow	55 l/s
Weight without filter	17.6 kg
Weight with filter	18.3 kg

Table 6- 14 PM240-2, IP20, frame size E, 380 V ... 480 V 3 AC

Article No. without filter	6SL3210-1PE28-8ULO	6SL3210-1PE31-1ULO
Article No. with filter	6SL3210-1PE28-8ALO	6SL3210-1PE31-1ALO
LO base load power	45 kW	55 kW
LO base load input current	86 A	104 A
LO base load output current	90 A	110 A
HO base load power	37 kW	45 kW
HO base load input current	78 A	94 A
HO base load output current	75 A	90 A
Fuse according to IEC	3NA3832 (125 A)	3NA3836 (160 A)
Fuse according to UL, class J	125 A	150 A
Power loss without filter	1.29 kW	1.65 kW
Power loss with filter	1.30 kW	1.67 kW
Required cooling air flow	83 l/s	83 l/s
Weight without filter	26.4 kg	26.4 kg
Weight with filter	28.4 kg	28.4 kg

Table 6- 15 PM240-2, IP20, frame size F, 380 V ... 480 V 3 AC

Article No. without filter	6SL3210-1PE31-5ULO	6SL3210-1PE31-8ULO	6SL3210-1PE32-1ULO
Article No. with filter	6SL3210-1PE31-5ALO	6SL3210-1PE31-8ALO	6SL3210-1PE32-1ALO
LO base load power	75 kW	90 kW	110 kW
LO base load input current	140 A	172 A	198 A
LO base load output current	145 A	178 A	205 A
HO base load power	55 kW	75 kW	90 kW
HO base load input current	117 A	154 A	189 A
HO base load output current	110 A	145 A	178 A
Fuse according to IEC	3NA3140 (200 A)	3NA3142 (224 A)	3NA3250 (300 A)
Fuse according to UL, class J	200 A	250 A	300 A
Power loss without filter	1.91 kW	2.46 kW	2.28 kW
Power loss with filter	1.93 kW	2.48 kW	2.30 kW
Required cooling air flow	153 l/s	153 l/s	153 l/s
Weight without filter	58 kg	58 kg	62 kg
Weight with filter	64 kg	64 kg	66 kg

Technical data

6.6 400 V converters

Table 6- 16 PM240-2, IP20, frame size F, 380 V ... 480 V 3 AC

Article No. without filter	6SL3210-1PE32-5UL0
Article No. with filter	6SL3210-1PE32-5AL0
LO base load power	132 kW
LO base load input current	242 A
LO base load output current	250 A
HO base load power	110 kW
HO base load input current	218 A
HO base load output current	205 A
Fuse according to IEC	3NA3252 (315 A)
Fuse according to UL, class J	350 A
Power loss without filter	2.98 kW
Power loss with filter	3.02 kW
Required cooling air flow	153 l/s
Weight without filter	62 kg
Weight with filter	66 kg

Table 6- 17 PM240-2, frame size G, 380 V ... 480 V 3 AC

Article No. with filter class C3	6SL3210-1PE33-0CLO	6SL3210-1PE33-7CLO	6SL3210-1PE34-8CLO
Article No. with filter class C2	6SL3210-1PE33-0ALO	6SL3210-1PE33-7ALO	6SL3210-1PE34-8ALO
LO base load power	160 kW	200 kW	250 kW
LO base load input current	300 A	365 A	470 A
LO base load output current	302 A	370 A	477 A
HO base load power	132 kW	160 kW	200 kW
HO base load input current	275 A	330 A	400 A
HO base load output current	250 A	302 A	370 A
Fuse according to IEC	3NA3254 (355 A)	3NA3260 (400 A)	3NA3372 (630 A)
Fuse according to UL, class J	400 A	500 A	600 A
Fuse according to IEC/UL	3NE1334-2 (500A)	3NE1334-2 (500A)	3NE1436-2 (630A)
Power loss with filter class C3	3.67 kW	4.62 kW	6.18 kW
Power loss with filter class C2	3.67 kW	4.62 kW	6.18 kW
Required cooling air flow	210 l/s	210 l/s	210 l/s
Weight with filter class C3	105 kg	113 kg	120 kg
Weight with filter class C2	107 kg	114 kg	122 kg

6.6.3 Current derating depending on the pulse frequency, 400 V converters

LO base load

Article number	LO power [kW]	Pulse frequency [kHz]							
		2	4 *)	6	8	10	12	14	16
		LO base load output current [A]							
6SL3210-1PE11-8 . L1	0.55	1.7	1.7	1.4	1.2	1	0.9	0.8	0.7
6SL3210-1PE12-3 . L1	0.75	2.2	2.2	1.9	1.5	1.3	1.1	1	0.9
6SL3210-1PE13-2 . L1	1.1	3.1	3.1	2.6	2.2	1.9	1.6	1.4	1.2
6SL3210-1PE14-3 . L1	1.5	4.1	4.1	3.5	2.9	2.5	2.1	1.8	1.6
6SL3210-1PE16-1 . L1	2.2	5.9	5.9	5	4.1	3.5	3	2.7	2.4
6SL321 . -1PE18-0 . L1	3	7.7	7.7	6.5	5.4	4.6	3.9	3.5	3.1
6SL3210-1PE21-1 . LO	4	10.2	10.2	8.7	7.1	6.1	5.1	4.6	4.1
6SL3210-1PE21-4 . LO	5.5	13.2	13.2	11.2	9.2	7.9	6.6	5.9	5.3
6SL321 . -1PE21-8 . LO	7.5	18	18	15.3	12.6	10.8	9	8.1	7.2
6SL3210-1PE22-7 . LO	11	26	26	22.1	18.2	15.6	13	11.7	10.4
6SL321 . -1PE23-3 . LO	15	32	32	27.2	22.4	19.2	16	14.4	12.8
6SL3210-1PE23-8 . LO	18.5	38	38	32.3	26.6	22.8	19	17.1	15.2
6SL3210-1PE24-5 . LO	22	45	45	38.3	31.5	27	22.5	20.3	18
6SL3210-1PE26-0 . LO	30	60	60	51	42	36	30	27	24
6SL321 . -1PE27-5 . LO	37	75	75	63.8	52.5	45	37.5	33.8	30
6SL3210-1PE28-8 . LO	45	90	90	76.5	63	54	45	40.5	36
6SL321 . -1PE31-1 . LO	55	110	110	93.5	77	---	---	---	---
6SL3210-1PE31-5 . LO	75	145	145	123.3	101.5	---	---	---	---
6SL3210-1PE31-8 . LO	90	178	178	151.3	124.6	---	---	---	---
Article number		Pulse frequency [kHz]							
		2 *)	4	6 **)	8 **)	10	12	14	16
		LO base load output current [A]							
6SL3210-1PE32-1 . LO	110	205	143.5	102.5	82	---	---	---	---
6SL321 . -1PE32-5 . LO	132	250	175	125	100	---	---	---	---
6SL3210-1PE33-0 .LO	160	302	211.4	151	120.8	---	---	---	---
6SL3210-1PE33-7 .LO	200	370	259	185	148	---	---	---	---
6SL3210-1PE34-8 .LO	250	477	333.9	238.5	190.8	---	---	---	---

*) Factory setting

**) Available from Functional State (FS) 12

The permissible motor cable length depends on the particular cable type and the pulse frequency that has been selected.

HO base load

Article number	HO power [kW]	Pulse frequency [kHz]							
		2	4 *)	6	8	10	12	14	16
		HO base load output current [A]							
6SL3210-1PE11-8 . L1	0.37	1.3	1.3	1.1	0.9	0.8	0.7	0.6	0.5
6SL3210-1PE12-3 . L1	0.55	1.7	1.7	1.4	1.2	1	0.9	0.8	0.7
6SL3210-1PE13-2 . L1	0.75	2.2	2.2	1.9	1.5	1.3	1.1	1	0.9
6SL3210-1PE14-3 . L1	1.1	3.1	3.1	2.6	2.2	1.9	1.6	1.4	1.2
6SL3210-1PE16-1 . L1	1.5	4.1	4.1	3.5	2.9	2.5	2.1	1.8	1.6
6SL321 . -1PE18-0 . L1	2.2	5.9	5.9	5	4.1	3.5	3	2.7	2.4
6SL3210-1PE21-1 . LO	3	7.7	7.7	6.5	5.4	4.6	3.9	3.5	3.1
6SL3210-1PE21-4 . LO	4	10.2	10.2	8.7	7.1	6.1	5.1	4.6	4.1
6SL321 . -1PE21-8 . LO	5.5	13.2	13.2	11.2	9.2	7.9	6.6	5.9	5.3
6SL3210-1PE22-7 . LO	7.5	18	18	15.3	12.6	10.8	9	8.1	7.2
6SL321 . -1PE23-3 . LO	11	26	26	22.1	18.2	15.6	13	11.7	10.4
6SL3210-1PE23-8 . LO	15	32	32	27.2	22.4	19.2	16	14.4	12.8
6SL3210-1PE24-5 . LO	18.5	38	38	32.3	26.6	22.8	19	17.1	15.2
6SL3210-1PE26-0 . LO	22	45	45	38.3	31.5	27	22.5	20.3	18
6SL321 . -1PE27-5 . LO	30	60	60	51	42	36	30	27	24
6SL3210-1PE28-8 . LO	37	75	75	63.8	52.5	45	37.5	33.8	30
6SL321 . -1PE31-1 . LO	45	90	90	76.5	63	54	45	40.5	36
6SL3210-1PE31-5 . LO	55	110	110	93.5	77	---	---	---	---
6SL3210-1PE31-8 . LO	75	145	145	123.3	101.5	---	---	---	---
Article number		Pulse frequency [kHz]							
		2 *)	4	6 **)	8 **)	10	12	14	16
		HO base load output current [A]							
6SL3210-1PE32-1 . LO	90	178	178	151.3	124.6	---	---	---	---
6SL321 . -1PE32-5 . LO	110	205	143.5	102.5	82	---	---	---	---
6SL3210-1PE33-0 .LO	132	250	175	125	100	---	---	---	---
6SL3210-1PE33-7 .LO	160	302	211.4	151	120.8	---	---	---	---
6SL3210-1PE34-8 .LO	200	370	259	185	148	---	---	---	---

*) Factory setting

**) Available from Functional State (FS) 12

The permissible motor cable length depends on the particular cable type and the pulse frequency that has been selected.

6.7 690 V converters

Motors for 690 V Power Modules

For the 690 V Power Modules, induction motors are permissible in the range from 50% ... 150% of the converter power without any restrictions.





Note

Motors for converter operation

Only use motors that are suitable for operation with converters with a DC link.

For 690 V Power Modules, motors with a suitable insulation system for 690 V converter operation are required (e.g. PREMIUM).

6.7.1 General data, 690 V converters

Property	Version
Line voltage	<ul style="list-style-type: none"> for systems according to IEC: 500 V ... 690 V 3 AC \pm 10% (in operation -20% < 1 min) for systems according to UL: 500 V ... 600 V 3 AC \pm 10% (in operation -20% < 1 min) filtered devices only with Slash Rating (600Y/347V AC)
Line supply configurations	Grounded TN/TT line supplies or non-grounded IT line supplies  Permissible line supplies (Page 44)
Line impedance	No restrictions
Power factor λ	> 0.9
Output voltage	0 V 3 AC ... 0.95 x input voltage (max.)
Input frequency	50 Hz ... 60 Hz, \pm 3 Hz
Output frequency	0 ... 550 Hz, depending on the control mode
Inrush current	< LO base load input current
Overvoltage category according to EN 61800-5-1	III for line supplies
Pulse frequency	2 kHz (factory setting), can be adjusted to 4 kHz Adjustable in steps of 2 kHz.  Current reduction as a function of the pulse frequency (Page 101) If you increase the pulse frequency, the converter reduces the maximum output current.
Short-circuit current (SCCR) and branch protection	Maximum permissible line short-circuit current \leq 100 kA rms  Branch protection and short-circuit strength according to UL and IEC https://support.industry.siemens.com/cs/ww/en/view/109801083
Braking methods	DC braking, compound braking, dynamic braking with integrated braking chopper
Degree of protection according to EN 60529	IP20; must be installed in a control cabinet
Protection class according to EN 61800-5-1	The converters are devices with protection class I
Touch protection according to EN 50274	DGUV regulation 3 when used for the intended purpose
Cooling in compliance with EN 60146	Forced air cooling AF
Safety Integrated	See function manual "Safety Integrated"  "Safety Integrated" function manual https://support.industry.siemens.com/cs/ww/en/view/109751320

Dependency of input voltage and output power

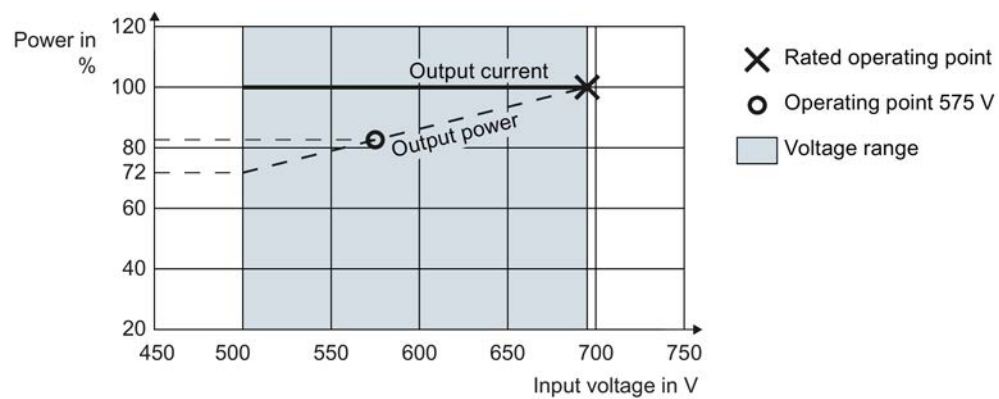

6.7.2 Specific technical data, 690 V converters

Table 6- 18 PM240-2, IP20, frame size D, 500 V ... 690 V 3 AC

Article No. - without filter	6SL3210-1PH21-4ULO	6SL3210-1PH22-0ULO	6SL3210-1PH22-3ULO
Article No. - with filter	6SL3210-1PH21-4ALO	6SL3210-1PH22-0ALO	6SL3210-1PH22-3ALO
LO base load power	11 kW	15 kW	18.5 kW
LO base load input current	14 A	18 A	22 A
LO base load output current	14 A	19 A	23 A
HO base load power	7.5 kW	11 kW	15 kW
HO base load input current	11 A	14 A	20 A
HO base load output current	11 A	14 A	19 A
Fuse according to IEC	3NA3807-6 (20 A)	3NA3810-6 (25 A)	3NA3812-6 (32 A)
Fuse according to UL, class J	20 A	25 A	30 A
Power loss without filter	0.35 kW	0.44 kW	0.52 kW
Power loss with filter	0.35 kW	0.45 kW	0.52 kW
Required cooling air flow	55 l/s	55 l/s	55 l/s
Weight without filter	17.4 kg	17.4 kg	17.4 kg
Weight with filter	18.9 kg	18.9 kg	18.9 kg

Table 6- 19 PM240-2, IP20, frame size D, 500 V ... 690 V 3 AC

Article No. - without filter	6SL3210-1PH22-7ULO	6SL3210-1PH23-5ULO	6SL3210-1PH24-2ULO
Article No. - with filter	6SL3210-1PH22-7ALO	6SL3210-1PH23-5ALO	6SL3210-1PH24-2ALO
LO base load power	22 kW	30 kW	37 kW
LO base load input current	25 A	33 A	40 A
LO base load output current	27 A	35 A	42 A
HO base load power	18.5 kW	22 kW	30 kW
HO base load input current	24 A	28 A	36 A
HO base load output current	23 A	27 A	35 A
Siemens fuse according to IEC	3NA3817-6KJ (40 A)	3NA3820-6KJ (50 A)	33NA3822-6 (63 A)
Fuse according to UL, class J	35 A	45 A	60 A
Power loss without filter	0.60 kW	0.77 kW	0.93 kW
Power loss with filter	0.60 kW	0.78 kW	0.94 kW
Required cooling air flow	55 l/s	55 l/s	55 l/s
Weight without filter	17.4 kg	17.4 kg	17.4 kg
Weight with filter	18.9 kg	18.9 kg	18.9 kg

Table 6- 20 PM240-2, IP20, frame size E, 500 V ... 690 V 3 AC

Article No. - without filter	6SL3210-1PH25-2ULO	6SL3210-1PH26-2ULO
Article No. - with filter	6SL3210-1PH25-2ALO	6SL3210-1PH26-2ALO
LO base load power	45 kW	55 kW
LO base load input current	50 A	59 A
LO base load output current	52 A	62 A
HO base load power	37 kW	45 kW
HO base load input current	44 A	54 A
HO base load output current	42 A	52 A
Siemens fuse according to IEC	3NA3824-6 (80A)	3NA3824-6 (80A)
Fuse according to UL, class J	80 A	80 A
Power loss without filter	1.07 kW	1.30 kW
Power loss with filter	1.08 kW	1.31 kW
Required cooling air flow	83 l/s	83 l/s
Weight without filter	27.1 kg	27.1 kg
Weight with filter	28.5 kg	28.5 kg

Table 6- 21 PM240-2, IP20, frame size F, 500 V ... 690 V 3 AC

Article No. - without filter	6SL3210-1PH28-0ULO	6SL3210-1PH31-0ULO	6SL3210-1PH31-2ULO
Article No. - with filter	6SL3210-1PH28-0ALO	6SL3210-1PH31-0ALO	6SL3210-1PH31-2ALO
LO base load power	75 kW	90 kW	110 kW
LO base load input current	78 A	97 A	111 A
LO base load output current	80 A	100 A	115 A
HO base load power	55 kW	75 kW	90 kW
HO base load input current	66 A	85 A	106 A
HO base load output current	62 A	80 A	100 A
Siemens fuse according to IEC	3NA3830-6 (100 A)	3NA3132-6 (125 A)	3NA3136-6 (160 A)
Fuse according to UL, class J	100 A	125 A	150 A
Power loss without filter	1.37 kW	1.74 kW	1.95 kW
Power loss with filter	1.38 kW	1.76 kW	1.97 kW
Required cooling air flow	153 l/s	153 l/s	153 l/s
Weight without filter	61 kg	61 kg	61 kg
Weight with filter	65 kg	65 kg	65 kg

6.7 690 V converters

Table 6- 22 PM240-2, IP20, frame size F, 500 V ... 690 V 3 AC

Article No. - without filter	6SL3210-1PH31-4UL0
Article No. - with filter	6SL3210-1PH31-4AL0
LO base load power	132 kW
LO base load input current	137 A
LO base load output current	142 A
HO base load power	110 kW
HO base load input current	122 A
HO base load output current	115 A
Siemens fuse according to IEC	3NA3140-6 (200 A)
Fuse according to UL, class J	200 A
Power loss without filter	2.48 kW
Power loss with filter	2.51 kW
Required cooling air flow	153 l/s
Weight without filter	61 kg
Weight with filter	65 kg

Table 6- 23 PM240-2, frame size G, 500 V ... 690 V 3 AC

Article No. with filter	6SL3210-1PH31-7CLO	6SL3210-1PH32-1CLO	6SL3210-1PH32-5CLO
LO base load power	160 kW	200 kW	250 kW
LO base load input current	170 A	205 A	250 A
LO base load output current	171 A	208 A	250 A
HO base load power	132 kW	160 kW	200 kW
HO base load input current	160 A	185 A	225 A
HO base load output current	144 A	171 A	208 A
Fuse according to the IEC/UL	3NE1227-0 (250A)	3NE1230-0 (315A)	3NE1331-0 (350A)
Power loss	2.94 kW	3.70 kW	4.64 kW
Required cooling air flow	210 l/s	210 l/s	210 l/s
Weight	114 kg	114 kg	114 kg

6.7.3 Current derating depending on the pulse frequency, 690 V converters

LO base load

Article number	LO power [kW]	Pulse frequency [kHz]	
		2 *)	4
		LO base load output current [A]	
6SL3210-1PH21-4 . LO	11	14	8.4
6SL3210-1PH22-0 . LO	15	19	11.4
6SL3210-1PH22-3 . LO	18.5	23	13.8
6SL3210-1PH22-7 . LO	22	27	16.2
6SL3210-1PH23-5 . LO	30	35	21
6SL321 . -1PH24-2 . LO	37	42	25.2
6SL3210-1PH25-2 . LO	45	52	31.2
6SL321 . -1PH26-2 . LO	55	62	37.2
6SL3210-1PH28-0 . LO	75	80	48
6SL3210-1PH31-0 . LO	90	100	60
6SL3210-1PH31-2 . LO	110	115	69
6SL3210-1PH31-4 . LO	132	142	85.2
6SL3210-1PH31-7CLO	160	171	102.6
6SL3210-1PH32-1CLO	200	208	124.8
6SL3210-1PH32-5CLO	250	250	150

*) Factory setting

The permissible motor cable length depends on the particular cable type and the pulse frequency that has been selected

6.8 Current rating for DC terminals

HO base load

Article number	HO power [kW]	Pulse frequency [kHz]	
		2 *)	4
		HO base load output current [A]	
6SL3210-1PH21-4 . LO	7.5	11	6.6
6SL3210-1PH22-0 . LO	11	14	8.4
6SL3210-1PH22-3 . LO	15	19	11.4
6SL3210-1PH22-7 . LO	18.5	23	13.8
6SL3210-1PH23-5 . LO	22	27	16.2
6SL3210-1PH24-2 . LO	30	35	21
6SL3210-1PH25-2 . LO	37	42	25.2
6SL3210-1PH26-2 . LO	45	52	31.2
6SL3210-1PH28-0 . LO	55	62	37.2
6SL3210-1PH31-0 . LO	75	80	48
6SL3210-1PH31-2 . LO	90	100	60
6SL3210-1PH31-4 . LO	110	115	69
6SL3210-1PH31-7CLO	132	144	85.2
6SL3210-1PH32-1CLO	160	171	102.6
6SL3210-1PH32-5CLO	200	208	124.8

*) Factory setting

The permissible motor cable length depends on the particular cable type and the pulse frequency that has been selected.

6.8 Current rating for DC terminals

Frame size	FSA	FSB	FSC	FSD	FSE	FSF	FSG
DC terminals	DCP/R1, DCN			R1, F3			
Current rating	10 A	20 A	30 A	44 A	68 A	130 A	130 A

6.9 Restrictions for special ambient conditions

Maximum current at low speeds

NOTICE

Overheating the converter due to unsuitable load

Loading the converter with a high output current and at the same time with a low output frequency can cause the current-conducting components in the converter to overheat. Excessively high temperatures can damage the converter or have a negative impact on the converter service life.

- Never operate the converter continuously with an output frequency = 0 Hz.
- Only operate the converter in the permissible operating range.

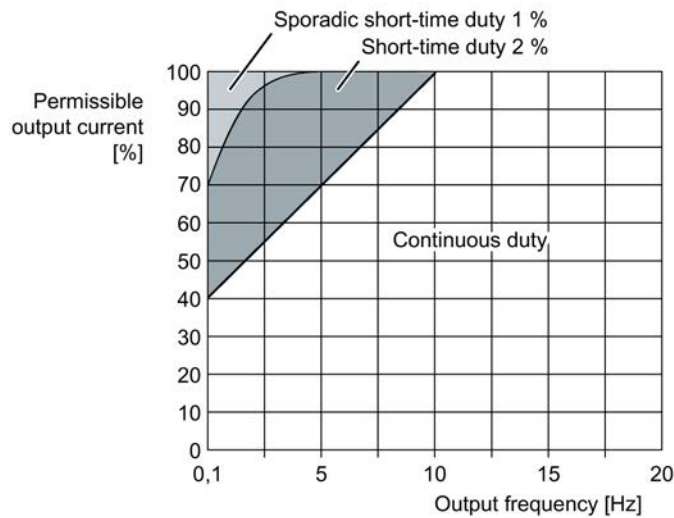

Figure 6-2 Permissible operating range of the converter

- Continuous operation:
Operating state that is permissible for the complete operating time.
- Short-time duty:
Operating state that is permissible for less than 2 % of the operating time.
- Sporadic short-time duty:
Operating state that is permissible for less than 1 % of the operating time.

Current reduction as a function of the installation altitude and ambient temperature

At installation altitudes above 1000 m the permissible converter output current is reduced.

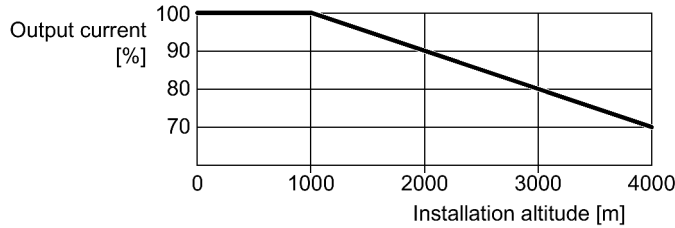

Figure 6-3 Current reduction as a function of the installation altitude

At installation altitudes above 1000 m, you can compensate the permissible converter output current to a certain extent using the ambient temperature. The following tables contain the details.

PM240-2, FSD-FSF, 200 V and 400 V converters

Table 6-24 Maximum permitted output current for loading according to LO

Installation altitude [m] up to	Ambient temperature [°C]									
	20	25	30	35	40	45	50	55	60	
	Output current in [%] when loading to LO									
1000	100					93	85	76	66	
1500	100				95	88	81	72	63	
2000	100			97	90	83	77	68	59	
2500	100		98	91	85	79	72	64	56	
3000	100	98	92	86	80	74	68	60	53	
3500	98	92	86	81	75	69	64	57	50	
4000	91	86	81	75	70	65	60	53	46	

Table 6- 25 Maximum permitted output current when loading according to HO

Installation altitude [m] up to	Ambient temperature [°C]									
	20	25	30	35	40	45	50	55	60	
	Output current in [%] when loading to HO									
1000	100						87	74		
1500	100						95	83	70	
2000	100				99	95	90	78	67	
2500	100			98	94	89	85	74	63	
3000	100		96	92	88	84	80	70	59	
3500	98	94	90	86	83	79	75	65	56	
4000	91	88	84	81	77	74	70	61	52	

PM240-2, FSA-FSC, 200 V and 400 V converters; FSD-FSF, 690 V converters; FSG, 400 V and 690 V converters

Table 6- 26 Maximum permitted output current for loading according to LO

Installation altitude [m] up to	Ambient temperature [°C]									
	20	25	30	35	40	45	50	55	60	
	Output current in [%] when loading to LO									
1000	100					93	85	60	35	
1500	100				95	88	81	57	33	
2000	100			97	90	83	77	54	32	
2500	100		98	91	85	79	72	51	30	
3000	100	98	92	86	80	74	68	48	28	
3500	98	92	86	81	75	69	64	45	26	
4000	91	86	81	75	70	65	60	42	25	

Table 6- 27 Maximum permitted output current when loading according to HO

Installation altitude [m] up to	Ambient temperature [°C]									
	20	25	30	35	40	45	50	55	60	
	Output current in [%] when loading to HO									
1000	100						75	50		
1500	100						95	71	48	
2000	100				99	95	90	68	45	
2500	100			98	94	89	85	64	43	
3000	100		96	92	88	84	80	60	40	
3500	98	94	90	86	83	79	75	56	38	
4000	91	88	84	81	77	74	70	53	35	

Also observe the maximum permissible ambient operating temperatures for the Control Unit and possibly the Operator Panel.

Permissible line supplies dependent on the installation altitude

- For installation altitudes ≤ 2000 m above sea level, it is permissible to connect the converter to any of the line supplies that are specified for it.
- For installation altitudes 2000 m ... 4000 m above sea level, the following applies:
 - Connection to a TN line system with grounded neutral point is permissible.
 - TN systems with grounded line conductor are not permitted.
 - The TN line system with grounded neutral point can also be supplied using an isolation transformer.
 - The phase-to-phase voltage does not have to be reduced.

Note

Using Power Modules connected to TN line supplies with voltages ≥ 600 V for installation altitudes 2000 m ... 4000 m

For voltages ≥ 600 V, the TN line supply must have a grounded neutral point established using an isolating transformer.

6.10 Electromagnetic compatibility of variable-speed drives

EMC (electromagnetic compatibility) means that the devices function satisfactorily without interfering with other devices and without being disrupted by other devices. EMC applies when the emitted interference (emission level) and the interference immunity are matched with each other.

The product standard IEC/EN 61800-3 describes the EMC requirements placed on "Variable-speed drive systems".

A variable-speed drive system (or Power Drive System PDS) consists of the converter as well as the associated electric motors and encoders including the connecting cables.

The driven machine is not part of the drive system.

Note

PDS as component of machines or systems

When you install PDS into machines or systems, additional measures may be required so that the product standards of these machines or systems is complied with. The machine or system builder is responsible for taking these measures.

Environments and categories

Environments

IEC/EN 61800-3 makes a distinction between the "first environment" and "second environment" - and defines different requirements for these environments.

- **First environment:**
Residential buildings or locations at which the PDS is directly connected to a public low-voltage supply without intermediate transformer.
- **Second environment:**
All industrial plant/systems or locations that are connected to the public grid through their own, dedicated transformer.

Categories

IEC/EN 61800-3 makes a distinction between four drive system categories:

- **Category C1:**
Drive systems for rated voltages < 1000 V for unrestricted use in the "first environment"
- **Category C2:**
Stationary PDS for rated voltages < 1000 V for operation in the "second environment".
Appropriately qualified personnel are required to install the PDS. An appropriately trained and qualified person has the necessary experience for installing and commissioning a PDS, including the associated EMC aspects.
Additional measures are required for operation in the "first environment".
- **Category C3:**
PDS for rated voltages < 1000 V - only for operation in the "second environment".
- **Category C4:**
PDS for IT line supplies for operation in complex systems in the "second environment".
An EMC plan is required.

6.10.1 Converter applications

Converters involve equipment used on a professional basis, deployed in certain areas of business and industry - and are not operated in the general public domain.

For an EMC-compliant installation, observe the information provided in the Configuration manual:

 EMC installation guideline
(<http://support.automation.siemens.com/WW/view/en/60612658>)

The devices described there are intended for operation in the first and second environments. Conditions for operation in the respective environment are subsequently listed.

6.10.1.1 Operation in the Second Environment

Interference immunity

You do not have to take any additional measures regarding interference immunity.

Interference emission - operation in the second environment, Category C2/C3

The drive system must comply with the following conditions in order to comply with the limit values of the second environment, Category C2/C3:

- The drive system is installed by appropriately qualified personnel in compliance with EMC regulations - and the installation notes provided in the manual.
- You use a shielded motor cable with low capacitance.
- The pulse frequency is not higher than the value set in the factory.
- The drive system is connected to a TN or TT line supply.
- You comply with the permissible motor cable length.



Length of the motor cable (Page 54).

- The converters are equipped with a Category C2/C3 line filter (internal or external).
 - **200 V converter frame size FSA ... FSC**
Converters with integrated filter are suitable for operation in the second environment, Category C2.
 - **200 V converter frame size FSD ... FSF**
The converters require an external filter, Category C2
 - **400 V converter**
Converters with integrated filter are suitable for operation in the second environment, Category C2.
 - **690 V converter**
Converters of frame sizes FSD and FSE with integrated filter are suitable for operation in the Second Environment, Category C2.
Converters of frame sizes FSF and FSG with integrated filter are suitable for operation in the Second Environment, Category C3.

With the external filters, from Section  Line filter (Page 122), the converters without integrated filter comply with the requirements of the Second Environment, Category C2 with reference to interference emission.

If you use converters without integrated filter or a filter other than those mentioned above, then you are responsible for verifying that the interference emission is limited.

You can use a dedicated radio interference suppression filter for each converter - or a common filter for several converters.



Further information on unfiltered devices can be found on the Internet:

Compliance with EMC limits with unfiltered devices
(<https://support.industry.siemens.com/cs/ww/en/view/109750634>)

Interference emission - operation in the second environment, Category C4

When connected to IT line supplies, only unfiltered converters are permissible. Use external filters without capacitors with respect to ground to limit symmetrical interference emission.

When necessary, contact one of our Solution Partners

(<https://www.automation.siemens.com/solutionpartner/partnerfinder/Home/Index?country=D&program=1&technology=19&lang=en>).

6.10.1.2 Operation in the First Environment

Interference immunity

You do not have to take any additional measures regarding interference immunity.

Interference emission - operation in the first environment, Category C2

In order that you may operate the drive system in the first environment, Category C2, then in addition to the requirements for use in the second environment, you must also observe the limit values related to harmonic currents.

Note

Maintaining the limit values for harmonic currents

With respect to the compliance with limits for harmonic currents, the EMC product standard EN61800-3 for PDS refers to compliance with standards EN 61000-3-2 and EN 61000-3-12.

Converter with an LO base load power ≤ 1 kW:

It cannot be guaranteed that the limit values are complied with corresponding to IEC 61000-3-2. The installation person/company or company operating the professionally used device must obtain authorization from the grid operator to connect the device regarding the harmonic currents.



Typical harmonic currents (Page 111)

Converters with an LO base load input current ≤ 16 A:

These devices are not subject to any limit values, and as a consequence can be connected to the public low-voltage grid without any prior consultation.

Converters with an LO base load input current > 16 A and ≤ 75 A

The drive system is in compliance with IEC/EN 61000-3-12 under the following preconditions:

- FSC Power Module, input voltage 3 AC 200 ... 240 V: You use a 3% or 4% line reactor.
- FSD Power Module, input voltage 3 AC 200 ... 240 V: A line reactor is not required
- FSB/FSC Power Module, input voltage 3 AC 380 ... 480 V: You use a 3% or 4% line reactor.
- Power Module FSD, input voltage 380 ... 480 V 3 AC: A line reactor is not required

Note

Line reactor

Contact our Solution Partners

(<https://www.automation.siemens.com/solutionpartner/partnerfinder/Home/Index?country=DE&program=1&technology=19&lang=en>) for a line reactor.

- Short-circuit power S_{sc} at the connection point of the customer's system to the public grid, is greater than or equal to the value according to the following formula:

$$S_{sc} \geq 120 \times \sqrt{3} \times V_{in} \times \text{LO base load input current}$$

Example: FSD converter, 400 V, input current, 70 A:

$$S_{sc} \geq 120 \times \sqrt{3} \times 400 \text{ V} \times 70 \text{ A}$$

This corresponds to a low-voltage transformer with an apparent power rating of 300 kVA ... 400 kVA with $V_k = 4\% \dots 6\%$

The installation company or company operating the equipment is responsible for ensuring that this equipment is only connected at a connection point with an appropriate short-circuit power (fault level).

If these preconditions do not apply, then the installation company or company operating the device must obtain authorization from the grid operator to connect the device regarding the harmonic currents.

 Typical harmonic currents (Page 111)

Converters with an LO base load current > 75A

There are no standard-related requirements for installing devices such as these. However, we recommend that the grid operator is informed when such a device is connected. 400 V converters conform to EN 61000-3-12.

Operation in residential environment (category C1)

Caution

In a residential environment, this product may cause radio interference, in which case supplementary mitigation measures may be required.

6.10.2 Typical harmonic currents

Table 6- 28 Typical harmonic currents (%) of the converter

Converter	Harmonic number							
	5th	7th	11th	13th	17th	19th	23rd	25th
FSA ... FSC, 200 V, 400 V ¹⁾	54	39	11	5.5	5	3	2	2
FSD ... FSF, 200 V ²⁾	28	14	8	6	5	4	3	3
FSD ... FSG, 400 V ²⁾	37	21	7	5	4	3	3	2
FSD ... FSG, 690 V ²⁾	34	18	8	5	4	3	3	2

¹⁾ Values relative to the LO input current for $V_k 1\%$

²⁾ Values relative to the LO input current

6.10.3 Harmonics at the power supply connection point according to IEC 61000-2-2

Description

IEC 61000-2-2 defines the compatibility level for voltage harmonics for the point of common coupling (PCC) with the public supply system.

For systems in which converters or other non-linear loads are widely used, a circuit feedback calculation that takes the individual system configuration into consideration should always be performed.

The converter with upstream Line Harmonics Filters (LHF) allows adherence to the compatibility level for voltage harmonics, regardless of what percentage of the overall load is made up of the converter load.

Note

The voltage distortions behavior in the frequency range of 2 kHz to 9 kHz (IEC 61000-2-2 AMD 1) and from 9 kHz to 150 kHz (IEC 61000-2-2 AMD 2) must be evaluated specifically for each system as a function of the impedance at the power supply connection point.

6.10.4 EMC limit values in South Korea

이 기기는 업무용(A 급) 전자파적합기기로서 판매자 또는 사용자는 이 점을 주의하시기 바라며, 가정외의 지역에서 사용하는 것을 목적으로 합니다.
 For sellers or users, please keep in mind that this device is an A-grade electromagnetic wave device. This device is intended to be used in areas other than home.

The EMC limit values to be observed for Korea correspond to the limit values of the EMC product standard for variable-speed electric drives EN 61800-3 of category C2 or the limit value class A, Group 1 to KN11.

By implementing appropriate additional measures, the limit values according to category C2 or limit value class A, Group 1, are observed for converter variants with integrated EMC filter class A.

Additional measures, such as the use of an additional RFI suppression filter (EMC filter), may be necessary especially with regard to other converter variants.

In addition, measures for EMC-compliant configuration of the plant or system are described in detail in this manual.

You can find additional information about EMC-compliant configuration of the plant or system on the Internet:

 EMC installation guideline
 (<http://support.automation.siemens.com/WW/view/en/60612658>)

The final statement on compliance with the applicable standard is given by the respective filter type information label attached to the individual device.

6.11 Protecting persons from electromagnetic fields

Overview

Protection of workers from electromagnetic fields is specified in the European EMF Directive 2013/35/EU. This directive is implemented in national law in the European Economic Area (EEA). Employers are obligated to design workplaces in such a way that workers are protected from impermissibly strong electromagnetic fields.

To this end, assessments and/or measurements must be performed for workplaces.

General conditions

The following general conditions apply for the evaluations and measurements:

1. The laws for protection from electromagnetic fields in force in individual EU member states can go beyond the minimum requirements of the EMF Directive 2013/35/EU and always take precedence.
2. The ICNIRP 2010 limits for the workplace are the basis for the assessment.
3. The 26th BImSchV (German Federal Emission Protection Regulation) defines 100 µT (RMS) for the assessment of active implants.
According to Directive 2013/35/EU, 500 µT (RMS) at 50 Hz is applicable here.
4. The routing of power cables has a significant impact on the electromagnetic fields that occur.

Install and operate the components inside metallic cabinets in compliance with the documentation and use shielded motor cables.



EMC-compliant installation of a machine or system (Page 25)

Evaluation of the converter

The converters are normally used in machines. The assessment and testing is based on DIN EN 12198.

Compliance with the limit values was assessed for the following frequencies:

- Line frequency 47 ... 63 Hz
- Pulse frequency, for example 4/8/16 kHz and multiples thereof, assessed up to a maximum of 100 kHz

The indicated minimum distances apply to the head and complete torso of the human body. Shorter distances are possible for extremities.

Table 6- 29 Minimum distances to the converter

Individuals without active implants		Individuals with active implants	
Control cabinet closed	Control cabinet open	Control cabinet closed	Control cabinet open
0 cm	Forearm length (approx. 35 cm)	Must be separately assessed depending on the active implant.	

Spare parts

Spare parts for frame sizes FSA ... FSC

	Article number		
	FSA	FSB	FSC
Fan kit	6SL3200-OSF12-0AA0	6SL3200-OSF13-0AA0	6SL3200-OSF14-0AA0

Spare parts for frame sizes FSD ... FSG

	Article number			
	FSD	FSE	FSF	FSG
Set of small components	6SL3200-OSK08-0AA0	6SL3200-OSK08-0AA0	6SL3200-OSK08-0AA0	6SL3200-OSK08-0AA0
Mechanical kit	6SL3200-OSM13-0AA0	6SL3200-OSM14-0AA0	6SL3200-OSM15-0AA0	6SL3200-OSM16-0AA0
Fan kit	6SL3200-OSF15-0AA0	6SL3200-OSF16-0AA0	6SL3200-OSF17-0AA0	6SL3200-OSF18-0AA0
Accessory kit / shield connection kit	6SL3262-1AD01-0DA0	6SL3262-1AE01-0DA0	6SL3262-1AF01-0DA0	6SL3262-1AG01-0DA0

Spare parts through Spares on Web



Spares on Web (<https://www.automation.siemens.com/sow>)

When you enter the article number and serial number of your device, you obtain a spare parts list current at the time of your inquiry.

Accessories

Available components

- Accessory kit / shield connection kit (includes the upper shield plate)
- Control Unit Adapter Kit CUA20, FSA ... FSG
- SINAMICS FSG adapter set, FSG
- External line filters, Class B (regarding conducted emissions) for frame sizes FSA ... FSC
No Class B filters are available for frame sizes FSD ... FSG.
- Line harmonics filters for frame sizes FSB ... FSG
- Line reactors for frame sizes FSA ... FSC
Line reactors are not required for frame sizes FSD ... FSG.
- Braking resistors
- Brake Relay or Safe Brake Relay for controlling a motor holding brake
- Output reactors
- Sine-wave filters
- dv/dt filter plus Voltage Peak Limiter

Connection components

Connection overview for the electrical components

 Connection overview (Page 51).

8.1 Top shield plate - FSD ... FSG

The shield plate is included in the accessory kit / shield connection kit. Article numbers:

 Spare parts (Page 115)

Fasten the shield plate as shown in the graphic:

- FSD and FSE: 2 x M5 / 3 Nm
- FSF and FSG: 4 x M8 / 23 Nm



8.2 Control Unit Adapter Kit CUA20

The Control Unit Adapter Kit CUA20 is an additional option providing a simple and alternative way of installing the devices in cabinets. Simply installed either to the left or right of the Power Module PM240-2, the adapter kit allows devices to be installed in cabinets with spatial and thermal isolation between the Power Module and the Control Unit. The Control Unit Adapter Kit CUA20 is applicable to PM240-2 of all the frame sizes.

Article number: 6SL3255-0BW01-0NA0

Scope of delivery

	①	Adapter for the Power Module
	②	Connecting cable (1.5 m)
	③	Adapter for the Control Unit
	Mounting screws are not included in the scope of delivery.	

Dimensions and drill patterns (mm)

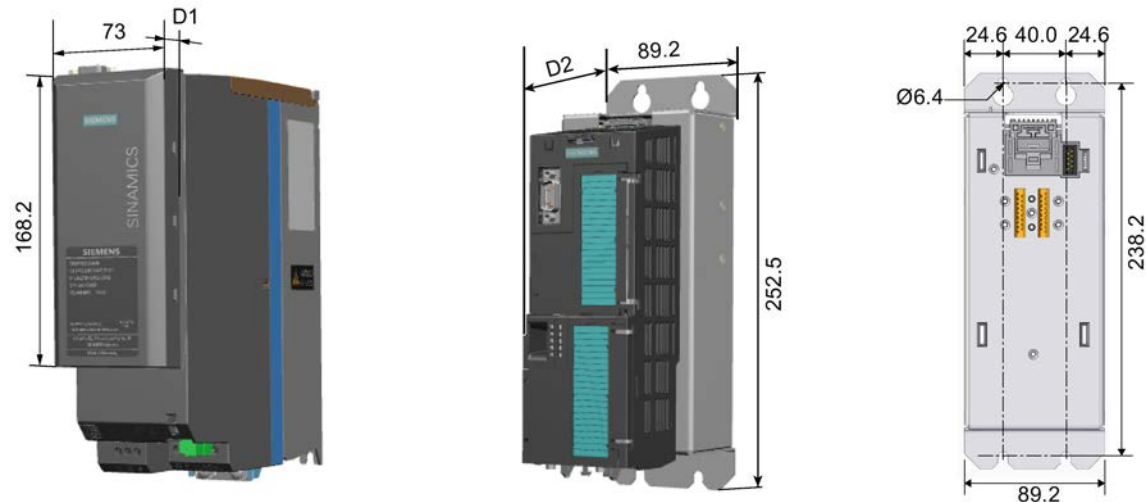

D1 ¹⁾		D2		
FSA...FSC	FSD...FSG	CU230P-2 ²⁾	CU240E-2 ²⁾	CU250S-2 ²⁾
29	/	117.8	100.3	121.1

¹⁾ Additional depth after installation

²⁾ Additional depth: with blanking cover or Operator Panel (11 mm); with SINAMICS G120 Smart Access (9 mm).

Installing

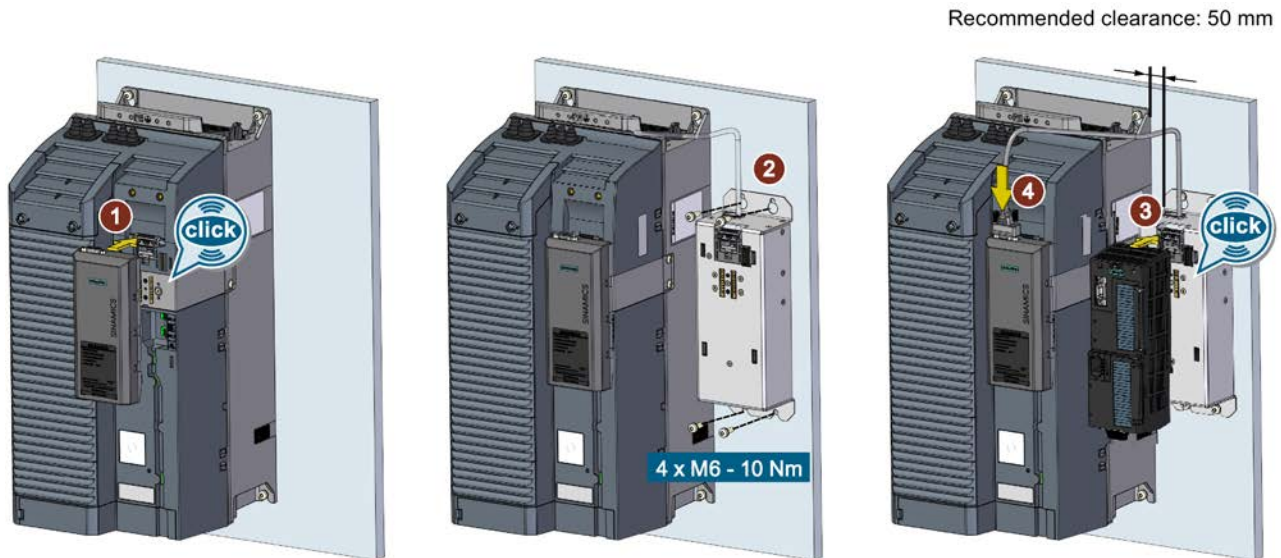

Note

It is recommended to install the adapter for the Control Unit on the right or left of the Power Module.

Note

After you finish the installation, properly tie up the excessive part of the connecting cable.

Shield connection of the STO/safety signal cable

Note

When using the Control Unit Adapter Kit CUA20, connect the shield of STO/safety signal cables to the shield plate of the Control Unit.

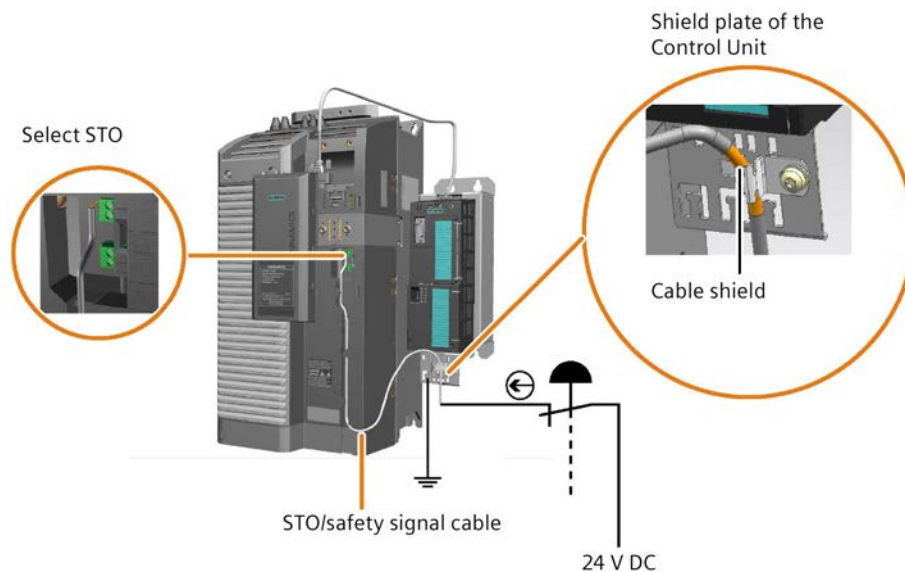

Technical specifications

Net weight	1032.8 g
Operating temperature	- 20 °C ... 60 °C
Shock and vibration	<ul style="list-style-type: none"> Storage: 1M2 according to EN 60721-3-1 Operation: 3M1 according to EN 60721-3-3
Protection against chemical substances	3C2 according to EN 60721-3-3
Standards and directives	CE, UL, TUV, EAC, RCM

For more information, see SINAMICS G120 Control Unit Adapter Kit CUA20 Compact Installation Instructions (<https://support.industry.siemens.com/cs/us/en/view/109780674>).

8.3 SINAMICS FSG Adapter Set

With the SINAMICS FSG Adapter Set, you can use cables with a maximum cross-section of 4 x 120 mm² per phase for line and motor connections on the PM240-2 FSG.

Article number: 6SL3266-2HG00-0BA0

Note

After installation, the FSG Adapter Set does not affect the technical specifications of the PM240-2 FSG.

Scope of delivery

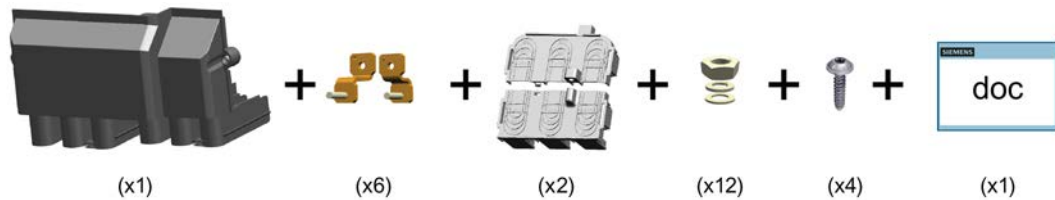

Applicable products

Product	Voltage (V)	Rated power (kW)	Article number
PM240-2 FSG	400	160	6SL3210-1PE33-0 .LO
		200	6SL3210-1PE33-7 .LO
		250	6SL3210-1PE34-8 .LO
	690	160	6SL3210-1PE31-7CLO
		200	6SL3210-1PE32-1CLO
		250	6SL3210-1PE32-5CLO

For more information about installing the FSG adapter set, see the SINAMICS FSG Adapter Set Compact Installation Instructions

(<https://support.industry.siemens.com/cs/ww/en/view/109781915>).

8.4 Line filter

Dimensions for mounting the line filter

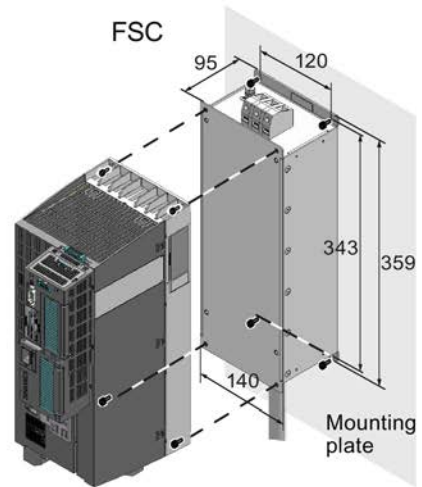
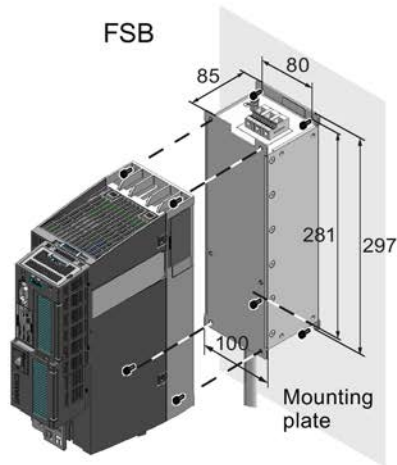
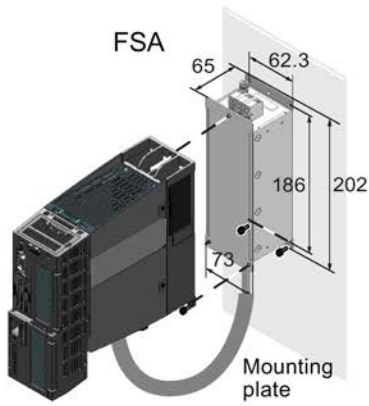

Fixing:
 - Line filter: 4 x M4 (⌀), 2.5 Nm
 - Converter: 3 x M4 (⌀), 2.5 Nm

Fixing:
 - Line filter: 4 x M4 (⌀), 2.5 Nm
 - Converter: 3 x M4 (⌀), 2.5 Nm

Fixing:
 - Line filter: 4 x M5 (⌀), 3 Nm
 - Converter: 3 x M5 (⌀), 3 Nm

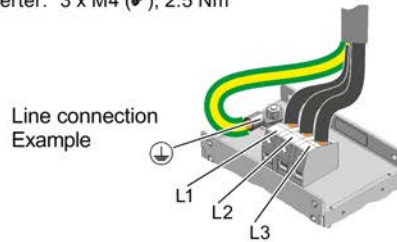

Table 8- 1 Technical data of the line filter (Class B regarding conducted emissions)

Article number	Power loss [W]	Connection		Weight [kg]
		Line supply and Power Module	PE	
6SL3203-0BE17-7BA0	13	2.5 mm ² / 0.8 Nm 14 AWG / 7 lbf in	2.5 mm ² / 2 Nm 14 AWG / 17.7 lbf in	1.75
6SL3203-0BE21-8BA0	22	6 mm ² / 1.8 Nm 10 AWG / 15.9 lbf in	2.5 mm ² / 2 Nm 14 AWG / 17.7 lbf in	4.0
6SL3203-0BE23-8BA0	50	16 mm ² / 4 Nm 6 AWG / 35.4 lbf in	16 mm ² / 32 Nm 6 AWG / 26.5 lbf in	7.3

Line filters are designed to IP20 degree of protection.

Table 8- 2 Assignment table

Power Module, 400 V			Line filter (Class B regarding conducted emissions)
Frame size	Article number	Power	Article number
FSA	6SL3210-1PE11-8UL1	0.55	6SL3203-0BE17-7BA0
	6SL3210-1PE12-3UL1	0.75	
	6SL3210-1PE13-2UL1	1.1	
	6SL3210-1PE14-3UL1	1.5	
	6SL3210-1PE16-1UL1	2.2	
	6SL3210-1PE18-0UL1	3.0	
FSB	6SL3210-1PE21-1UL0	4.0	6SL3203-0BE21-8BA0
	6SL3210-1PE21-4UL0	5.5	
	6SL3210-1PE21-8UL0	7.5	
FSC	6SL3210-1PE22-7UL0	11	6SL3203-0BE23-8BA0
	6SL3210-1PE23-3UL0	15	

8.5 Line harmonics filter

For applications out of the USA and Canada

The line harmonics filters reshape the distorted current back to the desired sinusoidal waveform.

With the line harmonics filters the converter fulfills the IEEE 519 standards.

For technical details refer to the following link:



Line harmonics filters

(<https://www.schaffner.com/products/download/product/datasheet/fn-3440-ecosine-50hz-passive-harmonic-filters/>)

Note

When using a line harmonics filter, a line reactor is not required and the permissible line voltage is 380 V ... 415 V 3 AC $\pm 10\%$ instead of 380 V ... 480 V 3 AC $\pm 10\%$ without a line harmonics filter.

For applications in the USA and Canada

For applications in the USA and Canada, use the line harmonics filters recommended by Siemens Product Partner for Drive Options.

For more information, see the link below:



Siemens Product Partner for Drive Options

(<https://new.siemens.com/global/en/company/topic-areas/partners/product-partners-industry.html>)

Assignment tables

Power Module, 400 V			Line harmonics filter
Frame size	Article number	Power [kW]	Article number Manufacturer: Schaffner EMV AG
FSD	6SL3210-1PE23-8 . LO	18.5	UAC:FN344019113E2FAJRX
	6SL3210-1PE24-5 . LO	22	UAC:FN344022115E2FAJRX
	6SL3210-1PE26-0 . LO	30	UAC:FN344030115E2FAJRX
	6SL321 . -1PE27-5 . LO	37	UAC:FN344037115E2FAJRX
FSE	6SL3210-1PE28-8 . LO	45	UAC:FN344045115E2FAJRX
	6SL321 . -1PE31-1 . LO	55	UAC:FN344055115E2FAJRX
FSF	6SL3210-1PE31-5 . LO	75	UAC:FN344075116E2FAJRX
	6SL3210-1PE31-8 . LO	90	UAC:FN344090116E2FAJRX
	6SL3210-1PE32-1 . LO	110	UAC:FN3440110118E2FAJRX
	6SL321 . -1PE32-5 . LO	132	UAC:FN3440132118E2FAJXX
FSG	6SL3210-1PE33-0 . LO	160	UAC:FN3440160118E2FAJXX
	6SL3210-1PE33-7 . LO	200	UAC:FN3440200118E2FAJXX
	6SL3210-1PE34-8 . LO	250	UAC:FN3440132118E2FAJXX *)

*) Two 132 kW filters in parallel are required.

If the expected input power exceeds the rating of the largest available filter, and a custom solution is not desired, then two or more filters can be wired in parallel. In this mode of operation, it is recommended to use filters with equal power ratings to ensure proper current sharing.

NOTICE**Line harmonic filters for Power Modules with 132 kW, 160 kW, 200 kW and 250 kW**

The following combinations must not be used with v/f control:

- Power Module 132 kW with LHF: UAC:FN3440132118E2FAJXX
- Power Module 160 kW with LHF: UAC:FN3440160118E2FAJXX
- Power Module 200 kW with LHF: UAC:FN3440200118E2FAJXX
- Power Module 250 kW with 2 LHF in parallel: UAC:FN3440132118E2FAJXX

When you use one of these combinations only the following settings of p1300 are allowed:

- P1300 = 20
- P1300 = 21
- P1300 = 22
- P1300 = 23

Clearances to other devices

Line harmonics filters are best installed as close as possible to the non-linear load. Ideally they are mounted next to the converter inside the electrical cabinet.

In order to ensure sufficient air flow, keep a clearance of minimum 150 mm above and below the filter to walls or other components.

It must be ensured that the environmental temperature is kept below 45 °C with appropriate thermal management (e.g. cabinet cooling). Filter operation in environments with higher temperatures require a temperature derating.

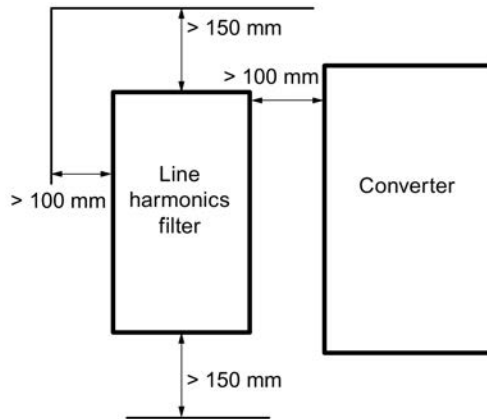

Dimensions, drilling patterns, and technical data

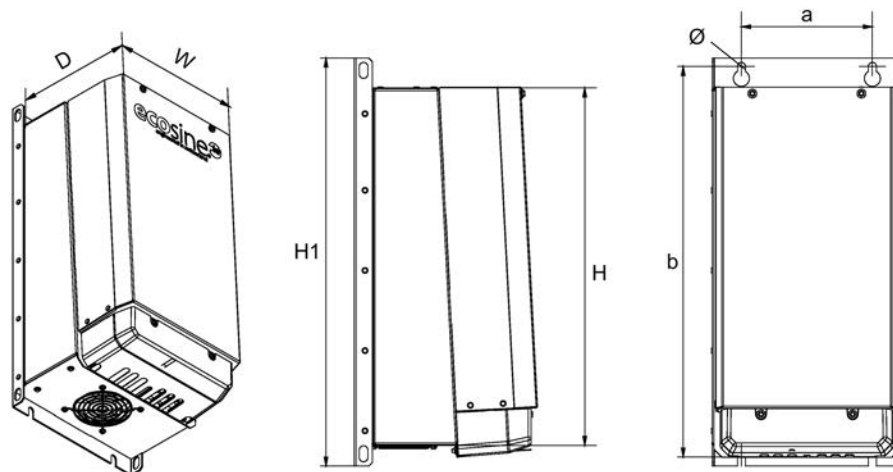

Article number	Weight [kg]	Dimensions [mm]				Drilling patterns [mm]			Power connections		
		D	W	H	H1	a	b	Ø	[mm ² / Nm]	[AWG / lbf.in]	PE / torque [Nm]
UAC:FN34406112E2XXJRX UAC:FN34408112E2XXJRX	19 23	221	210	430	483	150	460	7	0.4 ... 6 / 1.2	10 ... 22 / 10.6	M6 / 8
UAC:FN344011113E2FAJRX UAC:FN344015113E2FAJRX UAC:FN344019113E2FAJRX	32 36 37	252	260	491	560	180	540	11	0.75 ... 16 / 3	6 ... 18 / 26.6	M8 / 14
UAC:FN344022115E2FAJRX UAC:FN344030115E2FAJRX UAC:FN344037115E2FAJRX UAC:FN344045115E2FAJRX UAC:FN344055115E2FAJRX	53 55 66 73 75	319	290	635	705	220	680	11	10 ... 50 / 8	1/0 ... 8 / 70.8	M8 / 14
UAC:FN344075116E2FAJRX UAC:FN344090116E2FAJRX	126 147	386	353	863	960	280	920	11	10 ... 95 / 8	3/0 ... 8 / 70.8	M10 / 25
UAC:FN3440110118E2FAJRX UAC:FN3440132118E2FAJXX UAC:FN3440160118E2FAJXX UAC:FN3440200118E2FAJXX	175 194 219 267	456	462	1053	1150	390	1115	11	95 ... 240 / 10	3/0 ... 500 kcmil / 88.5	M10 / 25

8.6 Line reactor

A line reactor protects the converter when connected to dirty line supplies (line supply environment). A line reactor supports the overvoltage protection, smooths the harmonics in the line supply and buffers commutation dips.

Mounting position

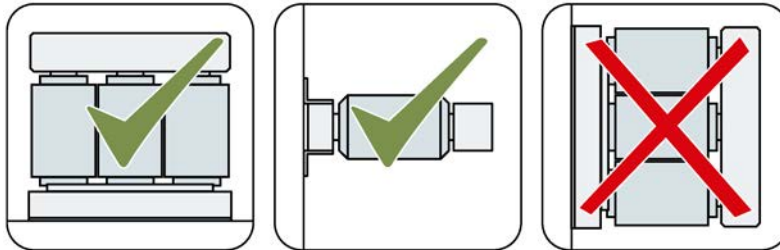

Clearances to other devices

Keep shaded areas free of any devices and components.

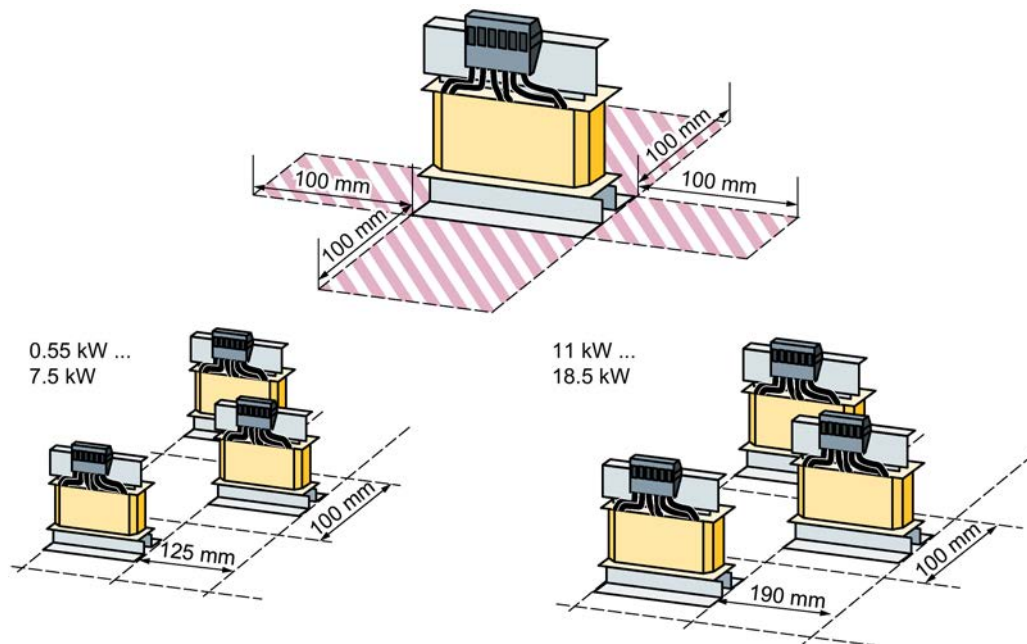
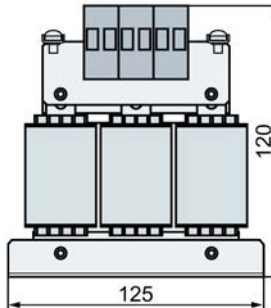
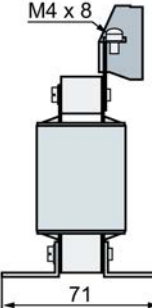
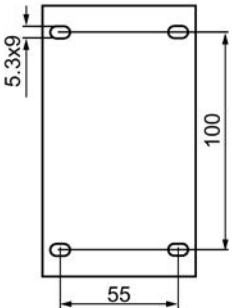
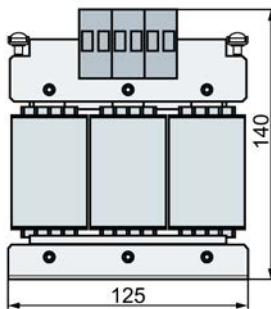
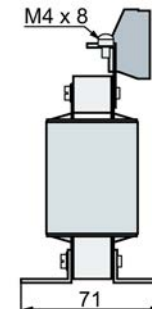
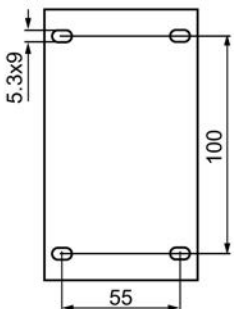
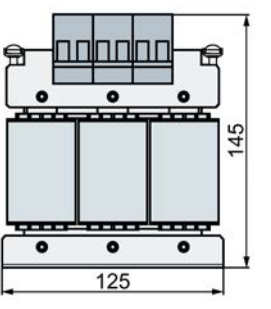
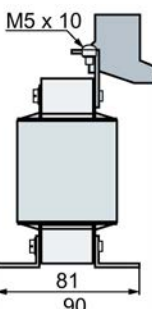
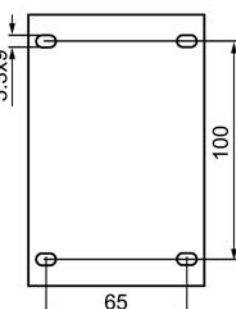
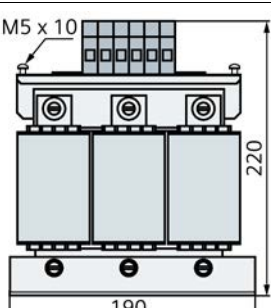
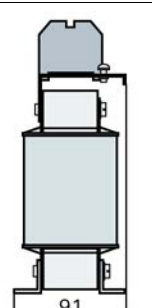
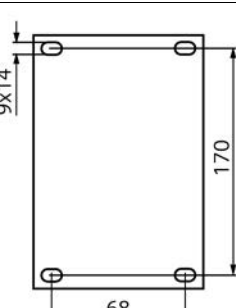

Figure 8-1 Clearances between the line reactors and other devices, examples for space-saving installation

Dimensions [mm] and drilling patterns

<p>Article number 6SL3203-0CE13-2AA0</p>				<p>Fixings: 4 × M5 screws 4 × M5 nuts 4 × M5 washers</p> <p>Tightening torque: 3.6 Nm</p>
<p>Article number 6SL3203-0CE21-0AA0</p>				<p>Fixings: 4 × M5 screws 4 × M5 nuts 4 × M5 washers</p> <p>Tightening torque: 3.6 Nm</p>
<p>Article number 6SL3203-0CE21-8AA0</p>				<p>Fixings: 4 × M5 screws 4 × M5 nuts 4 × M5 washers</p> <p>Tightening torque: 3.6 Nm</p>
<p>Article number 6SL3203-0CE23-8AA0</p>				<p>Fixings: 4 × M8 screws 4 × M8 nuts 4 × M8 washers</p> <p>Tightening torque: 14 Nm</p>

Assignment of line reactor to converter:

 Table 8-4 Assignment table (Page 130)

8.6 Line reactor

Table 8- 3 Technical data of the line reactors

Article number	Inductance [mH]	Line/load connection		PE connection	Weight [kg]
		[mm ² / nM]	[AWG / lbf in]	[mm ² / lbf in]	
6SL3203-OCE13-2AA0	2.5	2.5 / 0.8	14 / 7	M4 [3 / 26.5]	1.1
6SL3203-OCE21-0AA0	1	6 / 1.8	10 / 15.9	M4 [3 / 26.5]	2.1
6SL3203-OCE21-8AA0	0.5	6 / 1.8	10 / 15.9	M5 [5 / 44.3]	2.95
6SL3203-OCE23-8AA0	0.3	16 / 4	6 / 34.5	M5 [5 / 44.3]	7.80

The line reactors are designed to IP20 degree of protection.

Table 8- 4 Assignment table

Line reactors	Power Module, 400 V 3 AC		Power Module, 200 V 3 AC	
6SL3203-OCE13-2AA0	6SL3210-1PE11-8 .L1 6SL3210-1PE12-3 .L1 6SL3210-1PE13-2 .L1	FSA	6SL3210-1PB13-0 .LO 6SL321 .-1PB13-8 .LO	FSA
6SL3203-OCE21-0AA0	6SL3210-1PE14-3 .L1 6SL3210-1PE16-1 .L1 6SL321 .-1PE18-0 .L1	FSA	6SL3210-1PB15-5 .LO 6SL3210-1PB17-4 .LO 6SL321 .-1PB21-0 .LO	FSB
6SL3203-OCE21-8AA0	6SL3210-1PE21-1 .LO 6SL3210-1PE21-4 .LO 6SL321 .-1PE21-8 .LO	FSB	6SL3210-1PB21-4 .LO 6SL321 .-1PB21-8 .LO	FSC
6SL3203-OCE23-8AA0	6SL3210-1PE22-7 .LO 6SL321 .-1PE23-3 .LO	FSC	6SL3210-1PC22-2 .LO 6SL3210-1PC22-8 .LO	FSC

Line reactors for 1 AC 200 V

For converters with 1 AC 200 V connection, we recommend the following line reactors:

Line reactor ¹⁾	Power Module, 200 V 1 AC	
6SL3203-OCE21-0AA0	6SL3210-1PB13-0 .LO 6SL321 .-1PB13-8 .LO	FSA
6SL3203-OCE21-8AA0	6SL3210-1PB15-5 .LO 6SL3210-1PB17-4 .LO 6SL321 .-1PB21-0 .LO	FSB
6SL3203-OCE23-8AA0	6SL3210-1PB21-4 .LO 6SL321 .-1PB21-8 .LO	FSC

¹⁾ When using the recommended three phase line reactors on a single-phase supply, observe the connection note under the link below:

 Connecting to 1 AC 200V converter
(<https://support.industry.siemens.com/cs/ww/en/view/109486005>)

Alternatively, you can install the following line reactors produced by the BLOCK company:

PM240-2 frame size	Part number of the BLOCK line reactors
FSA	NKE 10 / 2.93
FSB	NKE 25 / 1.17
FSC	NEK 35 / 1.46

For more information about the technical properties and statements of the BLOCK reactors above, visit the Internet below:

 BLOCK line reactors (https://www.block.eu/en_US/products/reactors-filters/line-reactors/?tx_auwsolr_facettedlist%5Bf%5D%5Bphasen%5D%5B0%5D=1-phase&tx_auwsolr_facettedlist%5Bs%5D=productid-asc&cHash=a829ac0899c466b266a7dd36401ea489#facettedList)

8.7 Braking resistor

8.7.1 Installing a braking resistor

The braking resistor enables loads with a large moment of inertia to be braked quickly. During braking of the motor and the load, excess energy is fed back to the converter. This causes the voltage to rise in the DC link. The converter transfers the excess energy to the externally mounted braking resistor.

Note

When using a braking resistor, ensure that the braking power has been set in the parameter p0219.



! WARNING

Fire caused by an unsuitable or incorrectly installed braking resistor

Using an unsuitable or improperly installed braking resistor can cause fires and smoke to develop. Fire and smoke development can cause severe personal injury or material damage.

- Only use braking resistors that are approved for the converter.
- Install the braking resistor in accordance with regulations.
- Monitor the temperature of the braking resistor.

8.7.1.1 Braking resistor for frame sizes FSA ... FSF

Mounting position

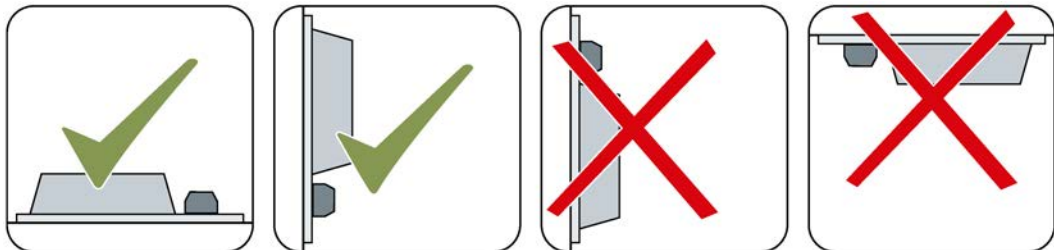

Mounting instructions

Mount the resistor on a heat resistant surface with a high thermal conductivity.

Do not cover the ventilation openings of the braking resistor.

You can mount the braking resistor either outside or inside the switchgear room. When mounted outside, the cooling air requirement for the switchgear room is lower.

Clearances to other devices

The following data are applicable for devices, frame sizes FSA ... FSC.

The clearances for braking resistors for devices, frame sizes FSD ... FSF are specified in the documentation, which is supplied with the braking resistor. You can find more information on the Internet: Braking resistors for SINAMICS PM240-2 FSD up to FSF (<https://support.industry.siemens.com/cs/us/en/view/109480104>)

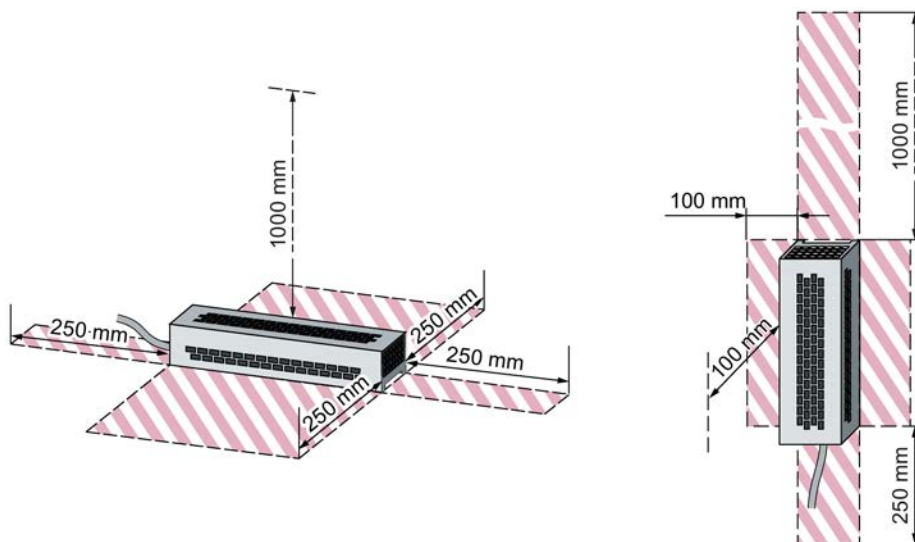
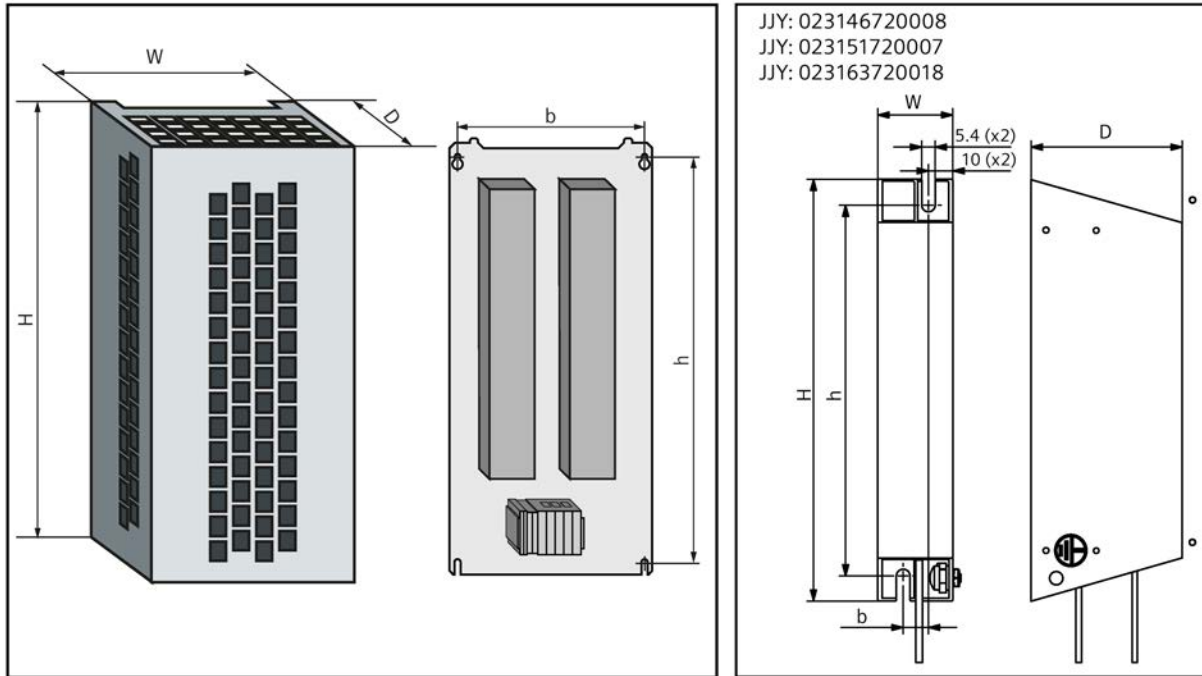

Figure 8-2 Minimum clearances for the braking resistor when mounting on a flat surface and for wall/panel mounting

Keep shaded areas free of any devices and components.

Dimensions and drilling patterns



Article number	Overall dimensions [mm]			Drilling dimensions [mm]		Fixing/torque	Converter frame size
	W	H	D	b	h		
for 200 V converters							
JJY:023146720008 ²⁾	30	167	60	72	150	M4 / 3 Nm	FSA
JJY:023151720007 ²⁾	30	217	60	72	200	M4 / 3 Nm	FSB
JJY:023163720018 ²⁾	30	337	60	142	320	M4 / 3 Nm	FSC
JJY:023433720001 ²⁾	30	337	120	217	325	M5 / 6 Nm	FSC
JJY:023422620002 ²⁾	220	470	180	187	430	M5 / 6 Nm	FSD
JJY:023423320001 ²⁾	220	560	180	187	500	M5 / 6 Nm	FSE
JJY:023434020003 ²⁾	350	630	180	317	570	M5 / 6 Nm	FSF
for 400 V converters							
6SL3201-0BE14-3AA0	105	295	100	72	266	M4 / 3 Nm	FSA
6SL3201-0BE21-0AA0	105	345	100	72	316	M4 / 3 Nm	FSA
6SL3201-0BE21-8AA0	175	345	100	142	316	M4 / 3 Nm	FSB
6SL3201-0BE23-8AA0	250	490	140	217	460	M5 / 6 Nm	FSC
JJY:023422620001 ²⁾	220	470	180	187	430	M5 / 6 Nm	FSD
JJY:023424020001 ²⁾	220	610	180	187	570	M5 / 6 Nm	FSD
JJY:023434020001 ²⁾	350	630	180	317	570	M5 / 6 Nm	FSE
JJY:023454020001 ^{1) 2)}							FSF
• JJY:023422620001 II	220	470	180	187	430	M5 / 6 Nm	(FSD)
• JJY:023434020001	350	630	180	317	570	M5 / 6 Nm	(FSE)
JJY:023464020001 ^{1) 2)}							FSF
• JJY:023434020001 II	350	630	180	317	570	M5 / 6 Nm	(FSE)
• JJY:023434020001	350	630	180	317	570	M5 / 6 Nm	(FSE)

Article number	Overall dimensions [mm]			Drilling dimensions [mm]		Fixing/torque	Converter frame size
	W	H	D	b	h		
for 690 V converters							
JJY:023424020002	220	610	180	187	570	M5 / 6 Nm	FSD
JJY:023434020002	350	630	180	317	570	M5 / 6 Nm	FSE
JJY:023464020002 ^{1) 2)}							FSF
• JJY:023434020002 II	350	630	180	317	570	M5 / 6 Nm	(FSE)
• JJY:023434020002	350	630	180	317	570	M5 / 6 Nm	(FSE)

Use the screws, nuts and washers when fixing the braking resistors

- 1) This braking resistor comprises two components, which must be connected in parallel on the plant or system side
 2) Manufacturer: Heine Resistors GmbH

8.7.1.2 Braking resistor for frame size FSG

Mounting position

The braking resistors are only suitable for vertical installation and not for installation on a wall.

Mounting instructions

Only a freestanding installation is allowed.

Objects must not be deposited on or above the braking resistor.

The installation should not be carried out near fire detectors as they could respond by the produced heat.

It has also to be ensured that the place of installation is able to dissipate the energy produced by the braking resistor.

Do not cover the ventilation openings of the braking resistor.

You can mount the braking resistor either outside or inside the switchgear room. When mounted outside, the cooling air requirement for the switchgear room is lower.

Clearances to other devices

During operation surface temperatures can exceed 80 °C. In view of this, sufficient distance from flammable objects must be maintained. A freestanding braking resistor installation with at least 200 mm of free space on each side for ventilation is required.

Dimensions

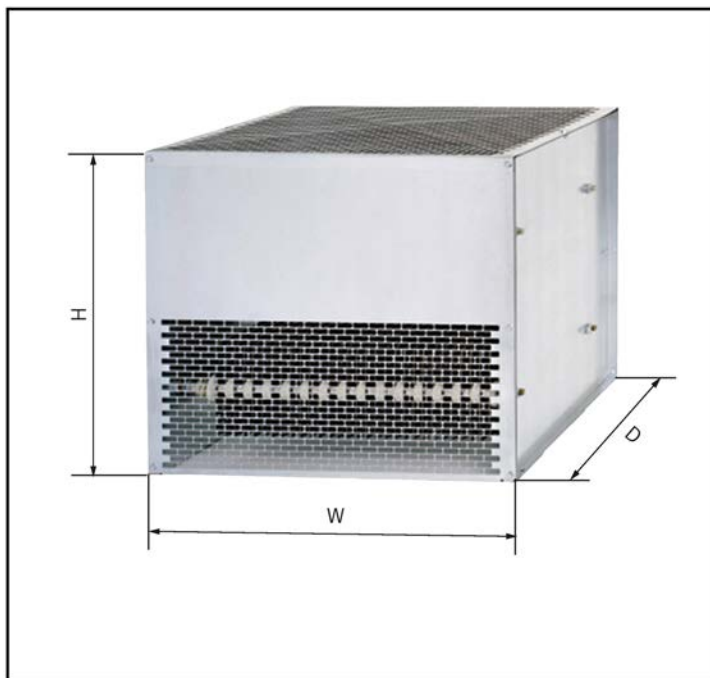

Article number	Overall dimensions [mm]			Converter frame size
	W	H	D	
for 400 V converters				
6SL3000-1BE32-5AA0	810	1325	485	FSG
for 690 V converters				
6SL3000-1BH32-5AA0	810	1325	485	FSG

8.7.2 Connecting a braking resistor

Some braking resistors have an integrated connection cable for the power connections (R1/R2) on the converter. Thus, the length and cross-section of the connection cable are given.

For braking resistors without integrated connection cable, the maximum cable length is 10 m. The required conductor cross-sections are contained in the following tables.

The conductor cross-sections for the temperature monitoring are contained in the Operating Instructions of the Control Unit of your converter.

For braking resistors without integrated connection cable, a short circuit-proof and ground fault-proof cable routing towards R1/R2 terminals must be provided. Ground the braking resistor directly to the control cabinet's grounding bar. The braking resistor must not be grounded using the PE terminal of the converter.

To comply with EMC requirements, observe the rules for shielding.

Additional information about EMC-compliant installation is available in the Internet:



EMC installation guideline

(<https://support.industry.siemens.com/cs/ww/en/view/60612658>)

Monitoring the temperature of the braking resistor without line contactor control

The braking contactors for FSA ... FSF converters are intrinsically safe braking resistors and shut down in the event of overheating.

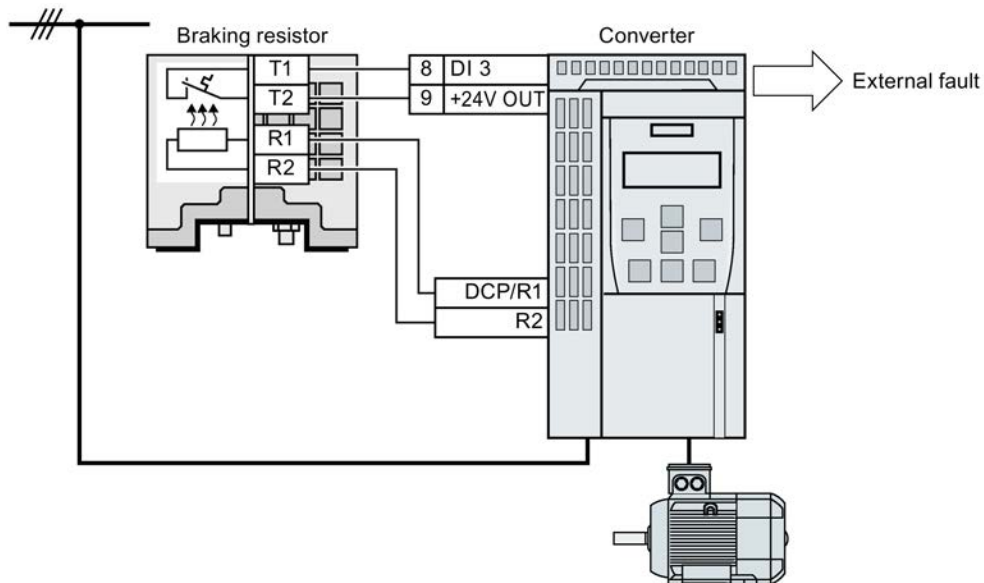

Figure 8-3 Connecting a braking resistor with temperature monitoring via digital input DI 3

Procedure

1. Connect the temperature monitoring system of the braking resistor (terminals T1 and T2 on the braking resistor) to a free digital input at the Control Unit of the converter.
2. When commissioning the drive, define the function of the digital input used as external fault, using p2106.

As an example with temperature monitoring via digital input DI 3: p2106 = 722.3.

You have ensured that the temperature is monitored.



Monitoring the temperature of the braking resistor with line contactor control

With respect to FSG converters, you not only have to monitor the temperature of the braking resistor but also have to ensure that the converter is disconnected from the line in the event of a braking resistor overload. To do so, activate the line contactor control via a digital output of the converter.

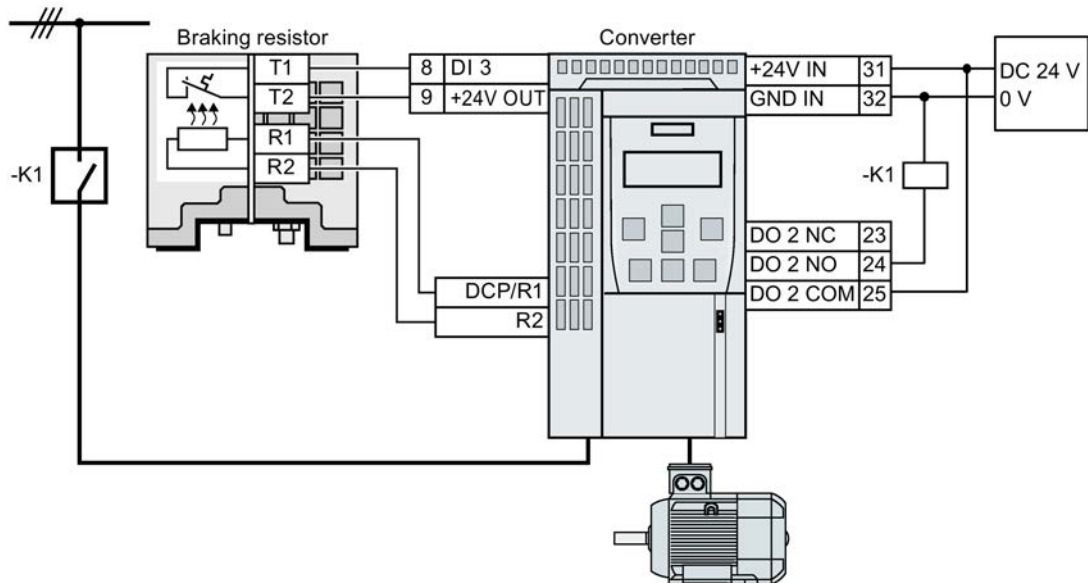

Figure 8-4 Connecting a braking resistor with temperature monitoring via digital input DI 3 and line contactor control (-K1) via digital output DO 2

Procedure

1. Connect the temperature monitoring system of the braking resistor (terminals T1 and T2 on the braking resistor) to a free digital input at the Control Unit of the converter.
2. When commissioning the drive, define the function of the digital input used as external fault, using p2106.

As an example with temperature monitoring via digital input DI 3: p2106 = 722.3.

3. Connect the digital output with the signal r0863.1 (line contactor control). For example for DO2 P0732 = 863.1

You have set the temperature monitoring and line contactor control.



8.7.3 Technical data of the braking resistor

For the converters, use the following or comparable braking resistors. The technical properties and statements made by the manufacturer apply.

Note

Braking resistors FSD ... FSF

Only use braking resistors that are UL approved, and have successfully passed the "Abnormal Operation Test" according to UL 508.

FSG braking resistors

Make sure that the monitoring system for braking resistor temperature shuts down the converter in the event of any overload.

Example:  Figure 8-4 Connecting a braking resistor with temperature monitoring via digital input DI 3 and line contactor control (-K1) via digital output DO 2 (Page 138)

Braking resistors for PM240-2, 200 V

Table 8-5 Technical data

Article number	Re- sistance	Maximum power, P_{max}	Connection R1 / R2	Degree of protec- tion	Power Module	
		Rated power P_{db}		Weight	Article numbers	Frame size
JJY:023146720008	200 Ω	0.75 kW	Connecting cable integrated in the braking resistor	IP20	6SL3210-1PB13-0 . LO 6SL321 . -1PB13-8 . LO	FSA
		37.5 W		0.5 kg		
JJY:023151720007	68 Ω	2.2 kW		IP20	6SL3210-1PB15-5 . LO 6SL3210-1PB17-4 . LO 6SL321 . -1PB21-0 . LO	FSB
		110 W		0.7 kg		
JJY:02 3163720018	37 Ω	4 kW		IP20	6SL3210-1PB21-4 . LO 6SL321 . -1PB21-8 . LO	FSC
		200 W		1.1 kg		
JJY:023433720001	20 Ω	7.5 kW		IP20	6SL3210-1PC22-2 . LO 6SL3210-1PC22-8 . LO	FSC
		375 W		2 kg		
JJY:023422620002	7.5 Ω	18.5 kW	10 mm ² / 0.5 Nm 8 AWG / 4.5 lbf in	IP21	6SL3210-1PC24-2UL0 6SL3210-1PC25-4UL0 6SL321 . -1PC26-8UL0	FSD
		930 W		7.0 kg		
JJY:023423320001	4.5 Ω	30 kW	16 mm ² / 1.2 Nm 6 AWG / 10.6 lbf in	IP21	6SL3210-1PC28-0UL0 6SL321 . -1PC31-1UL0	FSE
		1500 W		8.5 kg		
JJY:023434020003	2.5 Ω	55 kW	16 mm ² / 1.2 Nm 6 AWG / 10.6 lbf in	IP21	6SL3210-1PC31-3UL0 6SL3210-1PC31-6UL0 6SL321 . -1PC31-8UL0	FSF
		2750 W		13.5 kg		

Braking resistors for PM240-2, 400 V

Table 8- 6 Technical data

Article number	Re- sistance	Maximum power, P _{max}	Connection R1 / R2	Degree of protec- tion	Power Module		
		Rated power P _{db}		Weight	Article numbers	Frame size	
6SL3201-0BE14-3AA0	370 Ω	1.5 kW	2.5 mm ² / 0.5 Nm 14 AWG / 4.5 lbf in	IP20	1.5 kg	6SL3210-1PE11-8 . L1 6SL3210-1PE12-3 . L1 6SL3210-1PE13-2 . L1 6SL3210-1PE14-3 . L1	FSA
		75 W					
6SL3201-0BE21-0AA0	140 Ω	4 kW	2.5 mm ² / 0.5 Nm 14 AWG / 4.5 lbf in	IP20	1.8 kg	6SL321 . -1PE16-1 . L1 6SL321 . -1PE18-0 . L1	FSA
		200 W					
6SL3201-0BE21-8AA0	75 Ω	7.5 kW	4 mm ² / 0.5 Nm 12 AWG / 4.5 lbf in	IP20	2.7 kg	6SL3210-1PE21-1 . L0 6SL3210-1PE21-4 . L0 6SL321 . -1PE21-8 . L0	FSB
		375 W					
6SL3201-0BE23-8AA0	30 Ω	18.5 kW	6 mm ² / 0.8 Nm 10 AWG / 7.1 lbf in	IP20	6.2 kg	6SL3210-1PE22-7 . L0 6SL321 . -1PE23-3 . L0	FSC
		925 W					
JJY:023422620001	25 Ω	22 kW	10 mm ² / 0.8 Nm 8 AWG / 7.1 lbf in	IP21	7.0 kg	6SL3210-1PE23-8 . L0 6SL3210-1PE24-5 . L0	FSD
		1100 W					
JJY:023424020001	15 Ω	37 kW	10 mm ² / 0.8 Nm 8 AWG / 7.1 lbf in	IP21	9.5 kg	6SL3210-1PE26-0 . L0 6SL321 . -1PE27-5 . L0	FSD
		1850 W					
JJY:023434020001	10 Ω	55 kW	16 mm ² / 1.2 Nm 6 AWG / 4.5 lbf in	IP21	13.5 kg	6SL3210-1PE28-8 . L0 6SL321 . -1PE31-1 . L0	FSE
		2750 W					
JJY:023454020001 (JJY:023422620001 JJY:023434020001)	7.1 Ω	77 kW	10 mm ² / 0.8 Nm 8 AWG / 7.1 lbf in 16 mm ² / 1.2 Nm 6 AWG / 4.5 lbf in	IP21	20.5 kg	6SL3210-1PE31-5 . L0 6SL3210-1PE31-8 . L0	FSF
		3850 W					
JJY:023464020001 (JJY:023434020001 JJY:023434020001)	5 Ω	110 kW	16 mm ² / 1.2 Nm 6 AWG / 4.5 lbf in 16 mm ² / 1.2 Nm 6 AWG / 4.5 lbf in	IP21	27 kg	6SL3210-1PE32-1 . L0 6SL321 . -1PE32-5 . L0	FSF
		5500 W					
6SL3000-1BE32-5AA0	2.2 Ω	250 kW	70 mm ² / M10	IP20	120 kg	6SL3210-1PE33-0 . L0 6SL3210-1PE33-7 . L0 6SL3210-1PE34-8 . L0	FSG
		12.5 kW					

Braking resistors for PM240-2, 690 V

Table 8-7 Technical data

Article number	Re- sistance	Maximum power, P_{max}	Connection R1 / R2	Degree of protec- tion	Power Module	
		Rated power P_{db}		Weight	Article Nos.	Frame size
JJY:023424020002	31 Ω	37 kW	10 mm ² / 0.8 Nm 8 AWG / 7.1 lbf in	IP21	6SL3210-1PH21-4 . L0 6SL3210-1PH22-0 . L0 6SL3210-1PH22-3 . L0 6SL3210-1PH22-7 . L0 6SL3210-1PH23-5 . L0 6SL321 . -1PH24-2 . L0	FSD
		1850 W				
JJY:023434020002	21 Ω	55 kW	16 mm ² / 1.2 Nm 6 AWG / 4.5 lbf in	IP21	6SL3210-1PH25-2 . L0 6SL321 . -1PH26-2 . L0	FSE
		2750 W				
JJY:023464020002 (JJY:023434020002 II JJY:023434020002)	10.5 Ω	110 kW	16 mm ² / 1.2 Nm 6 AWG / 10.6 lbf in	IP21	6SL3210-1PH28-0 . L0 6SL3210-1PH31-0 . L0 6SL3210-1PH31-2 . L0 6SL3210-1PH31-4 . L0	FSF
		5500 W				
6SL3000-1BH32-5AA0	4.9 Ω	250 kW	70 mm ² / M10	IP20	6SL3210-1PH31-7CLO 6SL3210-1PH32-1CLO 6SL3210-1PH32-5CLO	FSG
		12.5 kW				

Load cycles for the braking resistors

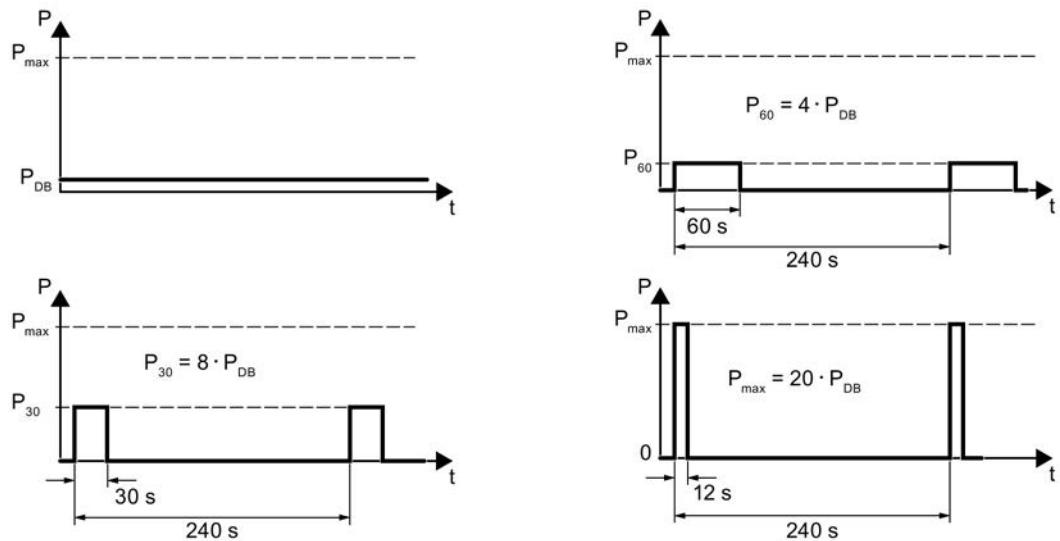

Figure 8-5 Pulse power, rated power and examples of the switch-on duration of the braking resistor

8.8 Brake Relays

The converter uses the Brake Relay to control the motor holding brake. Two types of Brake Relay exist:

- The Brake Relay controls the motor holding brake
- The Safe Brake Relay controls a 24 V motor holding brake and monitors the brake control for short-circuit or cable breakage.

Note

Brake Relay and Safe Brake Relay

There are no differences between the Brake Relay and the Safe Brake Relay in terms of installation and connection to the converter.

Connection to the converter

To ensure that you have the correct cable for connecting the Brake Relay irrespective of the converter size, you are supplied with four preassembled cables with different lengths. Connect the appropriate cable to the Brake Module and to the converter as shown below.

If you are using your own cable, ensure that the cable is insulated and rated for 600 V.

Connecting the motor holding brake via a PELV circuit

The Brake Relay must be connected to the protective conductor if the motor brake is supplied from a PELV circuit.

Note

When using the motor holding brake, ensure that the parameter p1215 has been set to 3.

Note

Both Brake Relays are not limited in terms of switching cycles and switching frequencies.

8.8.1 Technical data of the Brake Relay

	Brake Relay 6SL3252-0BB00-0AA0	Safe Brake Relay 6SL3252-0BB01-0AA0
Input voltage	via the Power Module	20.4 ... 28.8 VDC ¹⁾
Input current	via the Power Module	Max. 2.5 A
Max. connection cross-section:	2.5 mm ²	2.5 mm ²
Degree of protection	IP20	IP20
Switching capability of the NO contact	1-phase 250 VAC, 16 A 1-phase 30 VDC, 12 A	-
Output voltage	-	24 V
Output current	-	max. 2.5 A

¹⁾ External, controlled power supply required. Recommended voltage: 26 VDC

8.8.2 Connections and circuit diagrams

Brake Relay

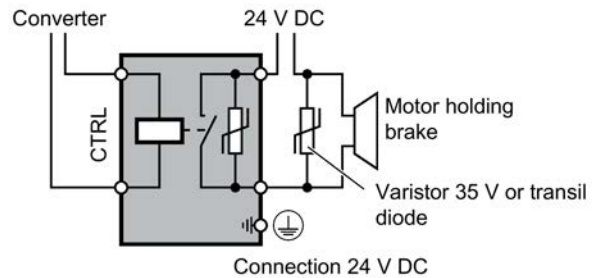
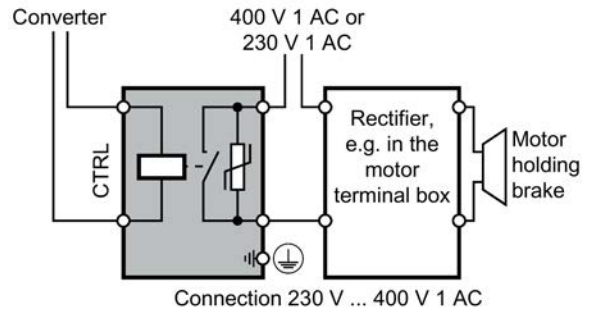
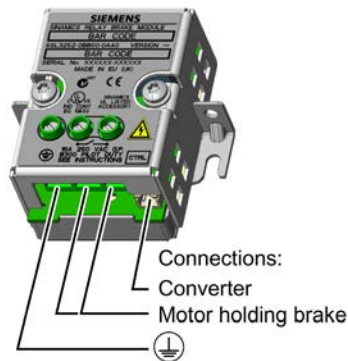

Safe Brake Relay

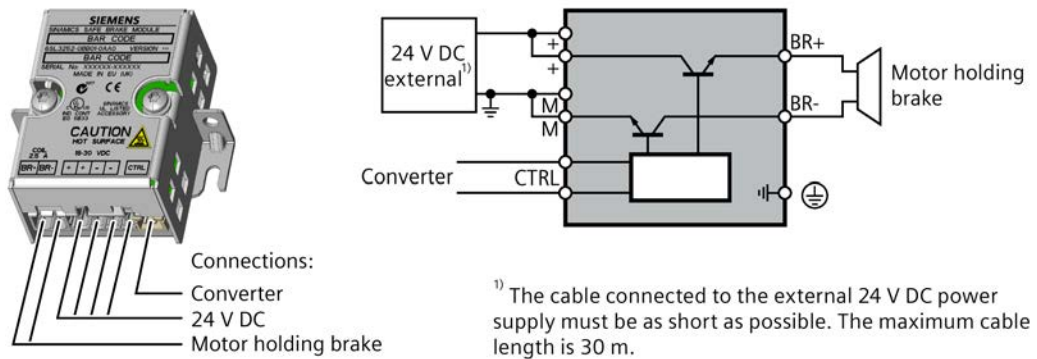

8.8.3 Mounting and connecting the Brake Relay

Installing the Brake Relay

- FSA ... FSC: Install the Brake Relay next to the Power Module.
- FSD ... FSG: Install the Brake Relay at the rear of the lower shield plate. Attach the Brake Relay before you install the shield plate.

Mounting the shield plates (Page 36)

FSD/FSE

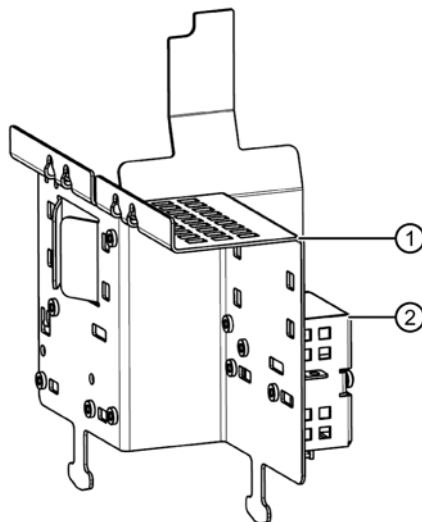

- ① Shield plates
- ② Brake Relay or Safe Brake Relay

FSF

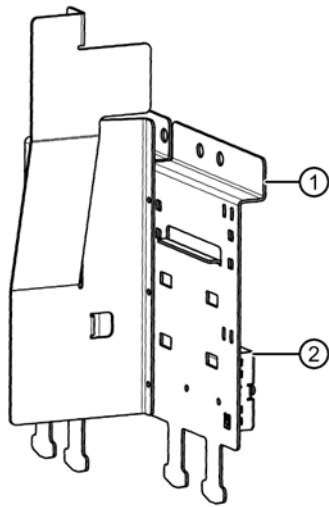

- ① Shield plates
- ② Brake Relay or Safe Brake Relay

FSG

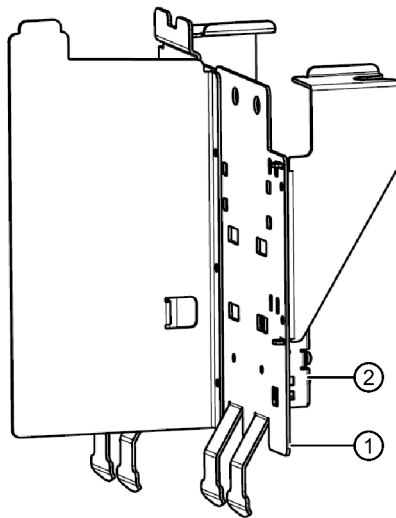

- ① Shield plates
- ② Brake Relay or Safe Brake Relay

Connecting the Brake Relay to the converter

The connector for the Brake Relay is located at the front of the Power Module. Lay the cable harness for the Brake Relay in the cable routing.

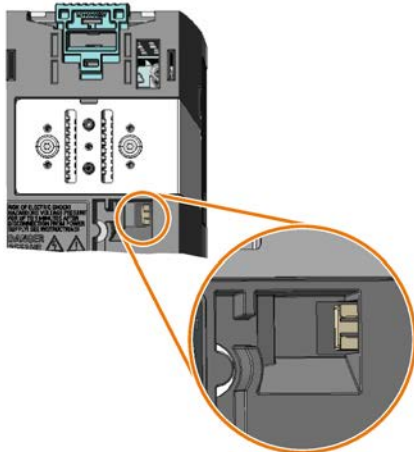

Brake relay connector for FSA ... FSC Power Modules without STO terminals

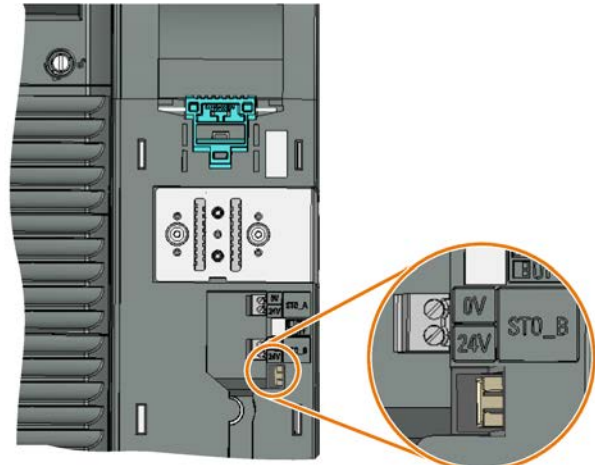

Brake relay connector for FSD ... FSF Power Modules with STO terminals

8.9 Output reactor

Output reactors reduce the voltage stress on the motor windings and the load placed on the converter as a result of capacitive recharging currents in the cables.

When using an output reactor, observe the following restrictions:

- The output frequency must not exceed 150 Hz.
- The pulse frequency must not exceed 4 kHz.

NOTICE

Damage to the output reactor by exceeding the maximum pulse frequency

The maximum permissible pulse frequency when using the output reactor is 4 kHz. The output reactor can be damaged if the pulse frequency is exceeded.

- When using an output reactor, the pulse frequency of the Power Module must not be higher than 4 kHz.

NOTICE

Damage to the output reactor if it is not activated during commissioning

The output reactor may be damaged if it is not activated during commissioning.

- Activate the output reactor during commissioning via parameter p0230.
- Activate the output reactor during commissioning according to the electric specifications.

For applications in the USA and Canada, you can also use the output reactors recommended by Siemens Product Partner for Drive Options. For more information, see the link below:



Siemens Product Partner for Drive Options

(<https://new.siemens.com/global/en/company/topic-areas/partners/product-partners-industry.html>)

Mounting position

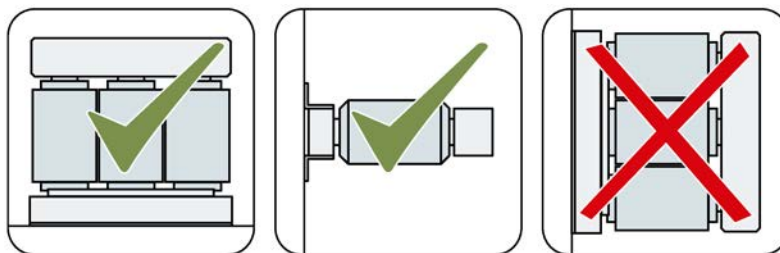

Clearances to other devices

Keep shaded areas free of any devices and components.

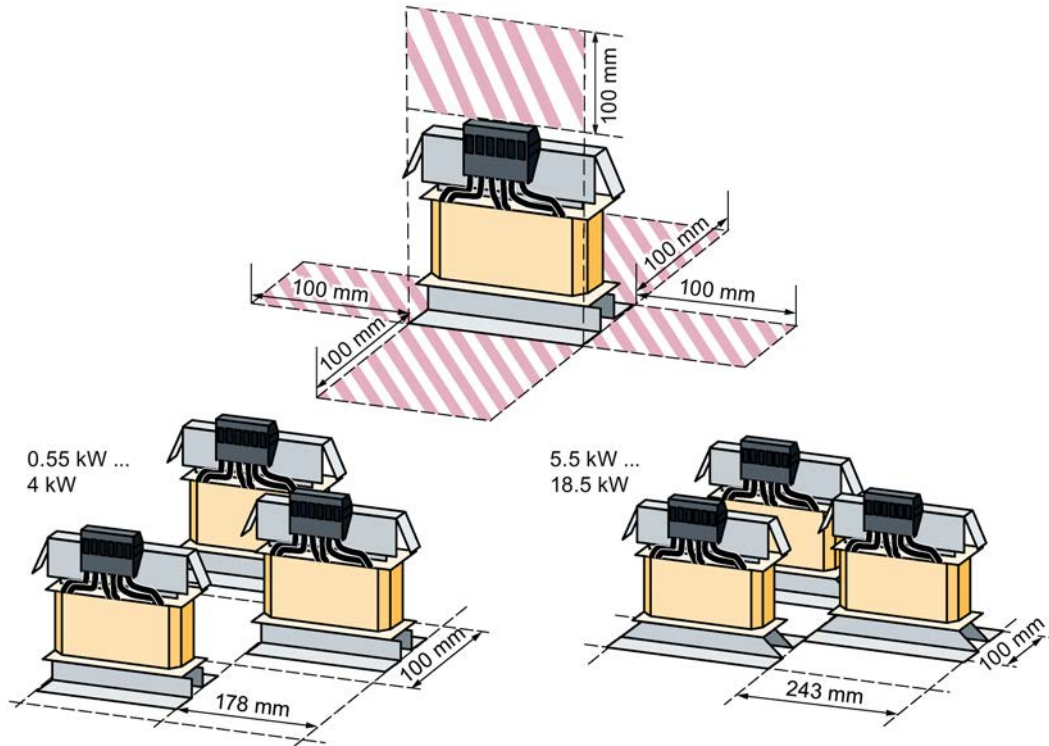

Minimum clearances of the output reactor to other devices, space-saving mounting examples

Dimensions, drilling patterns and weights for FSA ... FSC converters

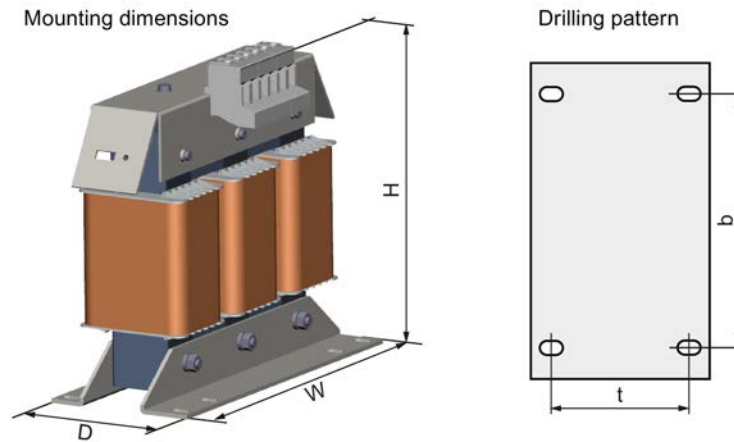

Table 8- 8 Dimensions and weights

Article number	Inductance [mH]	Overall dimensions [mm]			Drilling dimensions [mm]		Fixing/torque [Nm]	Weight [kg]
		W	H	D	b	t		
6SL3202-0AE16-1CA0	2.5	207	166	73	166	57	4 x M4 / 3	3.4
6SL3202-0AE18-8CA0	1.3	207	166	73	166	57	4 x M4 / 3	3.9
6SL3202-0AE21-8CA0	0.54	247	211	100	225	81	4 x M5 / 6	10.1
6SL3202-0AE23-8CA0	0.26	257	228	115	225	85	4 x M5 / 6	11.2

Output reactors are designed to IP20 degree of protection.

Table 8- 9 Connections to the Power Module and to the motor

Article number	Connection	
	Motor Module and motor	PE
6SL3202-0AE16-1CA0 6SL3202-0AE18-8CA0	Screw terminals 4 mm ² ; 0.6 ... 0.8 Nm	Threaded bolt M4 / 3 Nm
6SL3202-0AE21-8CA0	Screw terminals 10 mm ² ; 1.5 ... 1.8 Nm	Threaded bolt M5 / 5 Nm
6SL3202-0AE23-8CA0	Screw terminals 16 mm ² ; 2 ... 4 Nm	Threaded bolt M5 / 5 Nm

Assignment tables

Table 8- 10 Assignment table for 200 V Power Modules

Power Module			Output reactor
Frame size	Article number	Power [kW]	Article number
FSA	6SL3210-1PB13-0 . L0	0.55	6SL3202-0AE16-1CA0
FSA	6SL321 . -1PB13-8 . L0	0.75	
FSB	6SL3210-1PB15-5 . L0	1.1	
FSB	6SL3210-1PB17-4 . L0	1.5	6SL3202-0AE18-8CA0
FSB	6SL321 . -1PB21-0 . L0	2.2	6SL3202-0AE21-8CA0
FSC	6SL3210-1PB21-4 . L0	3	
FSC	6SL321 . -1PB21-8 . L0	4	
FSC	6SL321 . -1PC22-2 . L0	5.5	6SL3202-0AE23-8CA0
FSC	6SL3210-1PC22-8 . L0	7.5	

Table 8- 11 Assignment table for 400 V Power Modules

Power Module			Output reactor
Frame size	Article number	Power [kW]	Article number
FSA	6SL3210-1PE11-8 . L1	0.55	6SL3202-0AE16-1CA0
FSA	6SL3210-1PE12-3 . L1	0.75	
FSA	6SL3210-1PE13-2 . L1	1.1	
FSA	6SL3210-1PE14-3 . L1	1.5	
FSA	6SL3210-1PE16-1 . L1	2.2	
FSA	6SL321 . -1PE18-0 . L1	3	6SL3202-0AE18-8CA0
FSB	6SL3210-1PE21-1 . L0	4	6SL3202-0AE21-8CA0
FSB	6SL3210-1PE21-4 . L0	5.5	
FSB	6SL321 . -1PE21-8 . L0	7.5	
FSC	6SL3210-1PE22-7 . L0	11	6SL3202-0AE23-8CA0
FSC	6SL321 . -1PE23-3 . L0	15	

Dimensions, drilling patterns and weights for FSD ... FSG converters

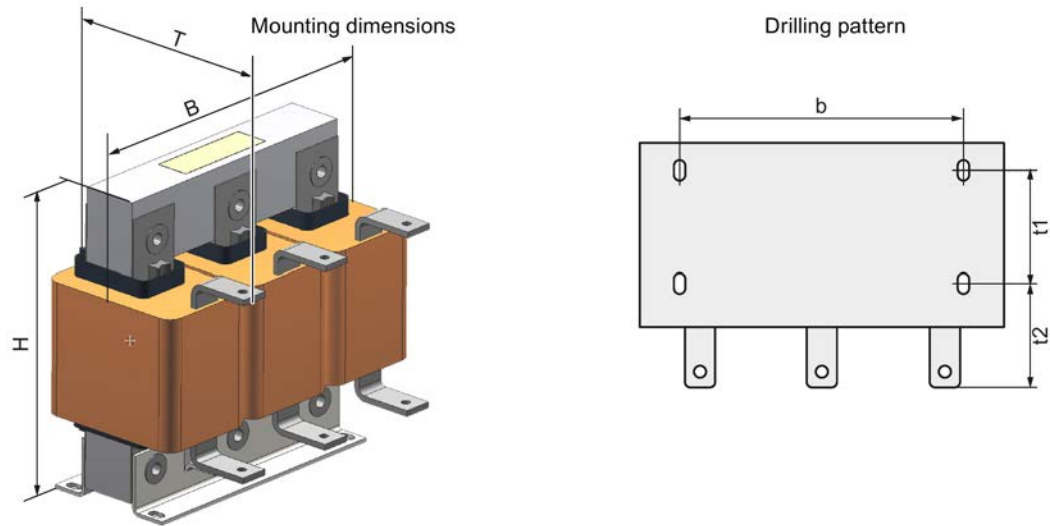

Figure 8-6 Dimensions and drilling patterns

Table 8- 12 Dimensions and weights

Article number	Inductance [mH]	Overall dimensions [mm]			Drilling dimensions [mm]			Fixing/torque [Nm]	Weight [kg]
		W	H	D	b	t1	t2		
6SE6400-3TC07-5ED0	/	270	248	209	200	102	91.5	4 x M8 / 25	26.5
6SE6400-3TC14-5FD0	/	350	321	288	264	140	134	4 x M8 / 25	57
6SL3000-2BE32-1AA0	/	300	285	257	224	165	78	4 x M8 / 25	60
6SL3000-2BE32-6AA0	/	300	315	277	224	185	78	4 x M8 / 25	66
6SL3000-2BE33-2AA0	/	300	285	277	224	183	79	4 x M8 / 25	66
6SL3000-2BE33-8AA0	/	300	285	277	224	183	79	4 x M8 / 25	73
6SL3000-2BE35-0AA0	/	300	365	277	224	183	79	4 x M8 / 25	100
JTA:TEU2532-0FP00-4EA0 ¹⁾	1.5	264	255	131	249	101	/	4 x M6 / 10	18
JTA:TEU 9932-0FP00-4EA0 ¹⁾	1.2	264	270	159	249	129	/	4 x M6 / 10	26
JTA:TEU 9932-0FS00-OEA0 ¹⁾	0.9	310	370	182	289	142	/	4 x M8 / 25	42
JTA:TEU 9932-1FC00-1BA0 ¹⁾	0.53	400	320	193	379	150	/	4 x M8 / 25	66
JTA:TEU 9932-0FV00-1BA0 ¹⁾	0.37	400	355	193	379	150	/	4 x M8 / 25	90
JTA:TEU 4732-0FA00-OBA0 ¹⁾	0.22	460	430	251	356	212	/	4 x M12 / 50	162

¹⁾ Manufacturer: mdexx Magnetronic Devices s.r.o.

The output reactors have a protection rating of IP00.

8.9 Output reactor

Table 8- 13 Connections to the Power Module and to the motor

Article number	Connection	
	Motor Module and motor	PE
6SE6400-3TC07-5ED0	Cable lug M6 / 6 Nm	Screw M6 / 10 Nm
6SE6400-3TC14-5FD0	Cable lug M8 / 13 Nm	Screw M8 / 25 Nm
6SL3000-2BE32-1AA0 6SL3000-2BE32-6AA0	Cable lug M10 / 25 Nm	Screw M8 / 25 Nm
6SL3000-2BE33-2AA0	Cable lug M10 / 25 Nm	Screw M8 / 25 Nm
6SL3000-2BE33-8AA0	Cable lug M10 / 50 Nm	Screw M8 / 25 Nm
6SL3000-2BE35-0AA0	Cable lug M12 / 50 Nm	Screw M8 / 25 Nm
JTA:TEU 2532-0FP00-4EA0	Screw terminals 16 mm ²	Screw terminals 16 mm ²
JTA:TEU 9932-0FP00-4EA0	Screw terminals 35 mm ²	Screw terminals 35 mm ²
JTA:TEU 9932-0FS00-0EA0	Screw terminals 70 mm ²	Screw terminals 70 mm ²
JTA:TEU 9932-1FC00-1BA0	Cable lug M8 / 13 Nm	Screw M6 / 10 Nm
JTA:TEU 9932-0FV00-1BA0	Cable lug M10 / 25 Nm	Screw M6 / 10 Nm
JTA:TEU 4732-0FA00-0BA0	Cable lug M10 / 25 Nm	Screw M6 / 10 Nm

Assignment tables

Table 8- 14 Assignment table for 200 V Power Modules

Power Module			Output reactor
Frame size	Article number	Power [kW]	Article number
FSD	6SL3210-1PC24-2UL0	11	6SE6400-3TC07-5ED0
FSD	6SL3210-1PC25-4UL0	15	
FSD	6SL321 . -1PC26-8UL0	18.5	
FSE	6SL3210-1PC28-0UL0	22	6SE6400-3TC14-5FD0
FSE	6SL321 . -1PC31-1UL0	30	
FSF	6SL3210-1PC31-3UL0	37	
FSF	6SL3210-1PC31-6UL0	45	
FSF	6SL321 . -1PC31-8UL0	55	

Table 8- 15 Assignment table for 400 V Power Modules

Power Module			Output reactor
Frame size	Article number	Power [kW]	Article number
FSD	6SL3210-1PE23-8 . LO	18.5	6SE6400-3TC07-5ED0
FSD	6SL3210-1PE24-5 . LO	22	
FSD	6SL3210-1PE26-0 . LO	30	
FSD	6SL321 . -1PE27-5 . LO	37	
FSE	6SL3210-1PE28-8 . LO	45	6SE6400-3TC14-5FD0
FSE	6SL321 . -1PE31-1 . LO	55	
FSF	6SL3210-1PE31-5 . LO	75	
FSF	6SL3210-1PE31-8 . LO	90	
FSF	6SL3210-1PE32-1 . LO	110	6SL3000-2BE32-1AA0
FSF	6SL321 . -1PE32-5 . LO	132	6SL3000-2BE32-6AA0
FSG	6SL3210-1PE33-0 . LO	160	6SL3000-2BE33-2AA0
FSG	6SL3210-1PE33-7 . LO	200	6SL3000-2BE33-8AA0
FSG	6SL3210-1PE34-8 . LO	250	6SL3000-2BE35-0AA0

Table 8- 16 Assignment table for 690 V Power Modules

Power Module			Output reactor
Frame size	Article number	Power [kW]	Article number
FSD	6SL3210-1PH21-4 . LO	11	JTA:TEU 2532-0FP00-4EA0
	6SL3210-1PH22-0 . LO	15	
	6SL3210-1PH22-3 . LO	18.5	
	6SL3210-1PH22-7 . LO	22	JTA:TEU 9932-0FP00-4EA0
	6SL3210-1PH23-5 . LO	30	
6SL3210-1PH24-2 . LO	37		
FSE	6SL3210-1PH25-2 . LO	45	JTA:TEU 9932-0FS00-0EA0
	6SL3210-1PH26-2 . LO	55	
FSF	6SL3210-1PH28-0 . LO	75	JTA:TEU 9932-1FC00-1BA0
	6SL3210-1PH31-0 . LO	90	
FSF	6SL3210-1PH31-2 . LO	110	JTA:TEU 9932-0FV00-1BA0
	6SL3210-1PH31-4 . LO	132	
FSG	6SL3210-1PH31-7CLO	160	JTA:TEU 4732-0FA00-0BA0
	6SL3210-1PH32-1CLO	200	
	6SL3210-1PH32-5CLO	250	

8.10 Sine-wave filter

The sine-wave filter limits the voltage gradient and the capacitive recharging currents which generally occur in converter operation. Therefore, when a sine-wave filter is used, longer screened motor cables are possible and the motor lifetime reaches the same values which are achieved when the motor is connected directly to the mains.

When using a sine-wave filter, observe the following restrictions:

- Operation is only permissible with pulse frequencies from 4 kHz ... 8 kHz.

Note

Operation with a pulse frequency of 2 kHz will overheat the sine-wave filter.

- It must be ensured that the automatic pulse frequency reductions are deactivated.
- The output frequency must not exceed 150 Hz.
- Operation and commissioning may only be performed with the motor connected because the sine-wave filter is not no-load proof.
- An output reactor is not required.

NOTICE
Damage to the sine-wave filter if it is not activated during commissioning
The sine-wave filter may be damaged if it is not activated during commissioning.
<ul style="list-style-type: none">• Activate the sine-wave filter during commissioning via parameter p0230.• Activate the sine-wave filter during commissioning according to the electric specifications.

For applications in the USA and Canada, you can also use the sine-wave filters recommended by Siemens Product Partner for Drive Options. For more information, see the link below:



Siemens Product Partner for Drive Options

(<https://new.siemens.com/global/en/company/topic-areas/partners/product-partners-industry.html>)

Assignment table

Power Module			Sine-wave filter
Frame size	Article number	Power [kW]	Article number
Power Module, 400 V			
FSA	6SL3210-1PE11-8 .L1	0.55	6SL3202-0AE20-3SA0
	6SL3210-1PE12-3 .L1	0.75	
	6SL3210-1PE13-2 .L1	1.1	
	6SL3210-1PE14-3 .L1	1.5	6SL3202-0AE20-6SA0
	6SL3210-1PE16-1 .L1	2.2	
	6SL321 .-1PE18-0 .L1	3.0	6SL3202-0AE21-1SA0
FSB	6SL3210-1PE21-1 .LO	4.0	6SL3202-0AE21-4SA0
	6SL3210-1PE21-4 .LO	5.5	
	6SL321 .-1PE21-8 .LO	7.5	6SL3202-0AE22-0SA0
FSC	6SL3210-1PE22-7 .LO	11	6SL3202-0AE23-3SA0
	6SL321 .-1PE23-3 .LO	15	

Dimensions

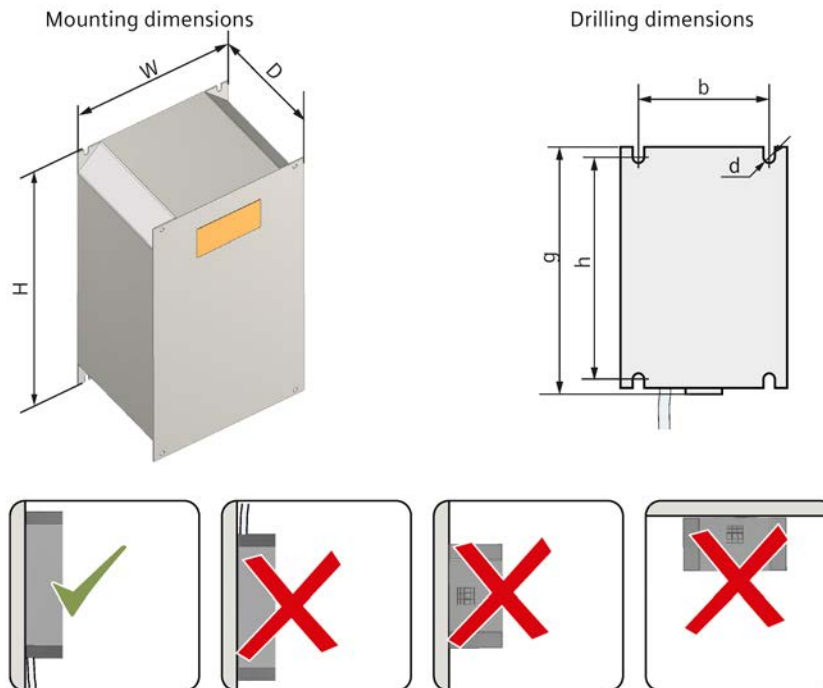

Sine-wave filter	Mounting dimensions (mm)			Drilling dimensions (mm)				Fixing / Torque (Nm)	Weight (kg)
	W	H	D	b	h	g	d		
6SL3202-0AE20-3SA0	76.5	200	110	56	187	202	4.8	4 x M4 / 2	2.6
6SL3202-0AE20-6SA0	76.5	200	110	56	187	202	4.8	4 x M4 / 2	3
6SL3202-0AE21-1SA0	153	270	100	133	258	286.5	4.8	4 x M4 / 2	6
6SL3202-0AE21-4SA0	153	270	100	133	258	286.5	4.8	4 x M4 / 2	10
6SL3202-0AE22-0SA0	189	336	140	167	323	351.5	5.5	4 x M5 / 3	12
6SL3202-0AE23-3SA0	189	336	140	167	323	351.5	5.5	4 x M5 / 3	23

Technical data

Sine-wave filter	P _{loss} 1)	Connection		Inductance p0233 (mH)	Capacitance p0234 (µF)	Degree of protection
		Power Module	Motor			
6SL3202-0AE20-3SA0	10	Integrated 500 mm	Screw terminals 6 mm ²	14	0.56	IP00
6SL3202-0AE20-6SA0	20	Integrated 500 mm	Screw terminals 6 mm ²	7	1.12	IP00
6SL3202-0AE21-1SA0	22	Integrated 500 mm	Screw terminals 6 mm ²	3.5	2.2	IP00
6SL3202-0AE21-4SA0	36	Integrated 500 mm	Screw terminals 6 mm ²	2.7	2.7	IP00
6SL3202-0AE22-0SA0	40	Integrated 500 mm	Screw terminals 6 mm ²	2.4	3.3	IP00
6SL3202-0AE23-3SA0	65	Integrated 500 mm	Screw terminals 10 mm ²	1.2	6.6	IP00

1) Power loss at 50 Hz

Further information

Further information is provided on the Internet below:



Sine-wave filter FSA-FSC

(<https://support.industry.siemens.com/cs/ww/en/view/109806049>)

8.11 dv/dt filter plus VPL

A combination of dv/dt filter and a voltage peak limiter (VPL) – dv/dt filter plus VPL – is available to suppress voltage peaks.

When using a dv/dt filter plus VPL, observe the following restrictions:

- The output frequency must not exceed 150 Hz.
- The pulse frequency must not exceed 4 kHz.

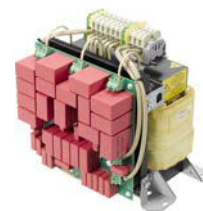

NOTICE

Damage to the dv/dt filter plus VPL if it is not activated during commissioning

The dv/dt filter plus VPL may be damaged if it is not activated during commissioning.

- Activate the dv/dt filter plus VPL during commissioning via parameter p0230.
- Activate the dv/dt filter plus VPL during commissioning according to the electric specifications.

NOTICE

Damage to the dv/dt filter plus VPL if the connection to the capacitor is not removed

The dv/dt filter plus VPL may be damaged if the connection to the capacitor of the common mode filter is not removed when the dv/dt filter plus VPL operates in the IT line system.

Further information is provided on the Internet:

-  Voltage limiter and dv/dt filter (https://www.mdexx.com/wp-content/uploads/2019/11/BAF-18-001-76_Instruction_manual.pdf)

For applications in the USA and Canada, you can also use the dv/dt filters plus VPL recommended by Siemens Product Partner for Drive Options. For more information, see the link below:

-  Siemens Product Partner for Drive Options (<https://new.siemens.com/global/en/company/topic-areas/partners/product-partners-industry.html>)

dv/dt filters plus VPL for PM240-2 Power Modules, 3 AC 400 V

Power Module		Power	dv/dt filter plus VPL Manufacturer: mdexx Mag- netronic Devices s.r.o
FSD	6SL3210-1PE23-8 .LO	18.5 kW	JTA:TEF1203-OHB
	6SL3210-1PE24-5 .LO	22 kW	JTA:TEF1203-OJB
	6SL3210-1PE26-0 .LO	30 kW	
FSD	6SL321 .-1PE27-5 .LO	37 kW	JTA:TEF1203-OKB
FSE	6SL3210-1PE28-8 .LO	45 kW	
FSE	6SL321 .-1PE31-1 .LO	55 kW	JTA:TEF1203-OLB
FSF	6SL3210-1PE31-5 .LO	75 kW	
FSF	6SL3210-1PE31-8 .LO	90 kW	JTA:TEF1203-OMB
	6SL3210-1PE32-1 .LO	110 kW	
	6SL321 .-1PE32-5 .LO	132 kW	

dv/dt filters plus VPL for PM240-2 Power Modules, 3 AC 690 V

Power Module		Power	dv/dt filter plus VPL Manufacturer: mdexx Mag- netronic Devices s.r.o
FSD	6SL3210-1PH21-4 .LO	11 kW	JTA:TEF1203-OGB
	6SL3210-1PH22-0 .LO	15 kW	
	6SL3210-1PH22-3 .LO	18.5 kW	
	6SL3210-1PH22-7 .LO	22 kW	JTA:TEF1203-OHB
	6SL3210-1PH23-5 .LO	30 kW	
	6SL3210-1PH24-2 .LO	37 kW	
FSE	6SL3210-1PH25-2 .LO	45 kW	JTA:TEF1203-OJB
	6SL3210-1PH26-2 .LO	55 kW	
FSF	6SL3210-1PH28-0 .LO	75 kW	JTA:TEF1203-OKB
	6SL3210-1PH31-0 .LO	90 kW	
	6SL3210-1PH31-2 .LO	110 kW	JTA:TEF1203-OLB
FSG	6SL3210-1PH31-4 .LO	132 kW	
	6SL3210-1PH31-7CLO	160 kW	JTA:TEF1203-OMB
	6SL3210-1PH32-1CLO	200 kW	
	6SL3210-1PH32-5CLO	250 kW	

Dimensions

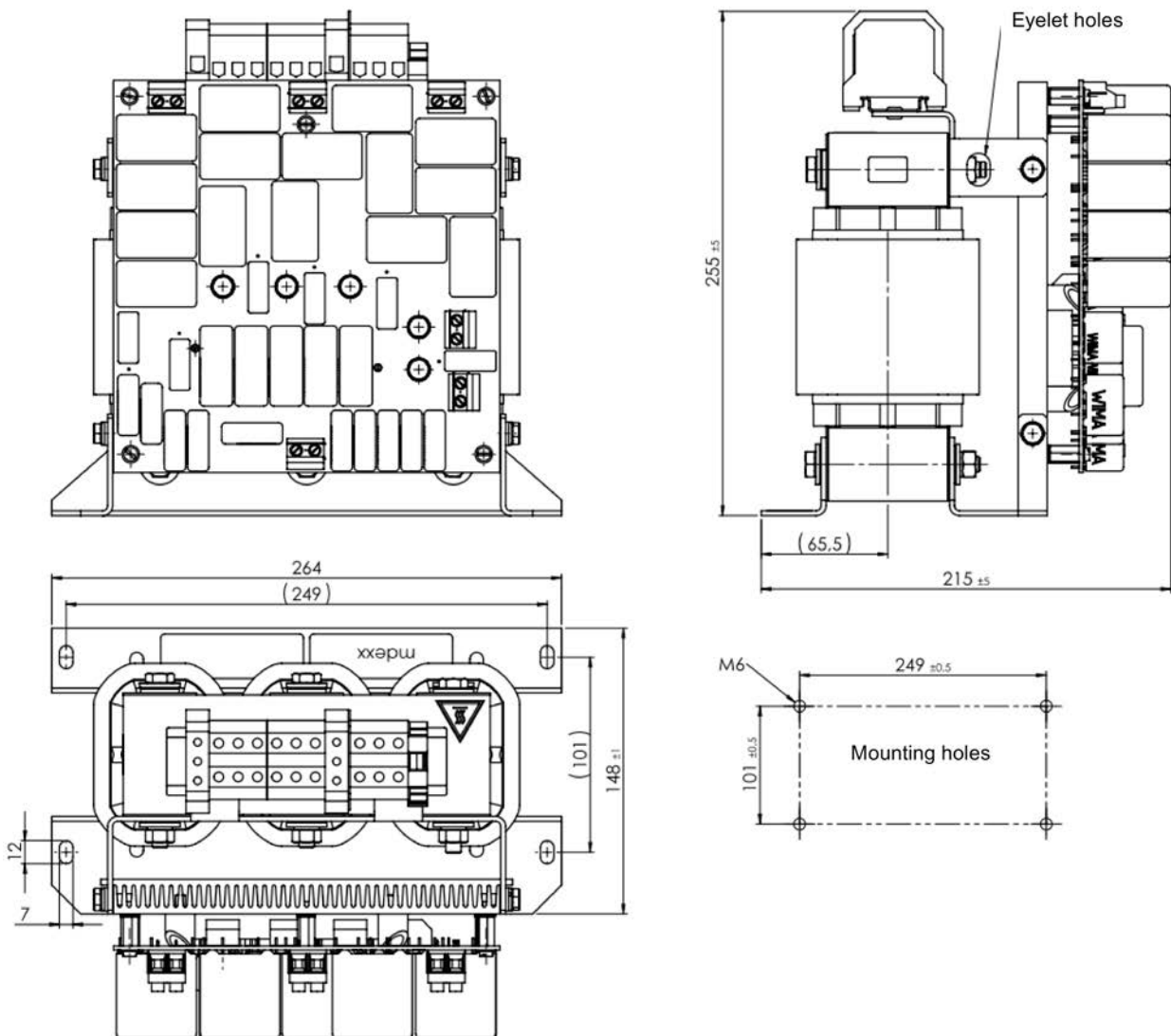

Figure 8-7 Dimensions for JTA:TEF1203-0GB

8.11 dv/dt filter plus VPL

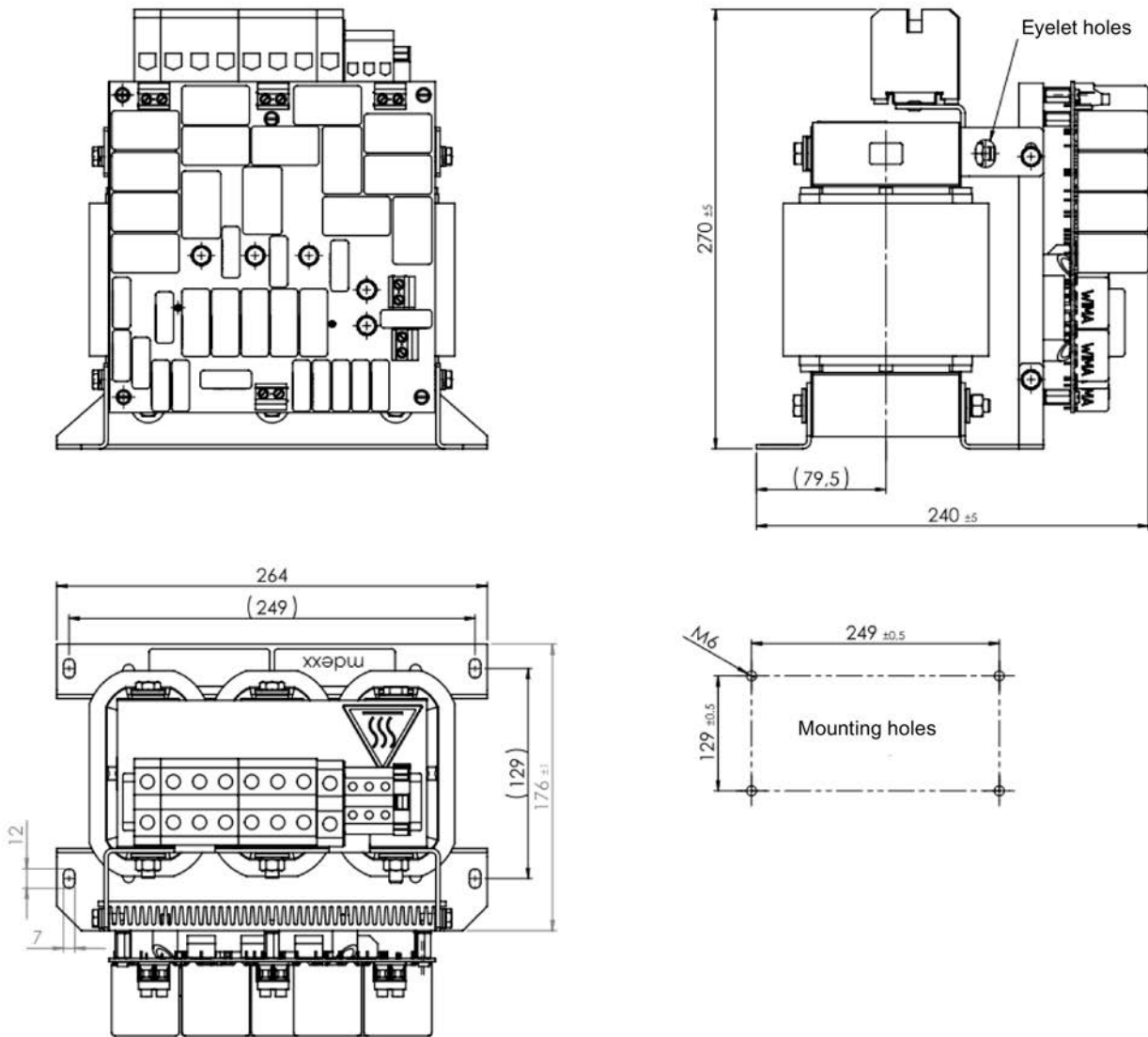

Figure 8-8 Dimensions for JTA:TEF1203-0HB

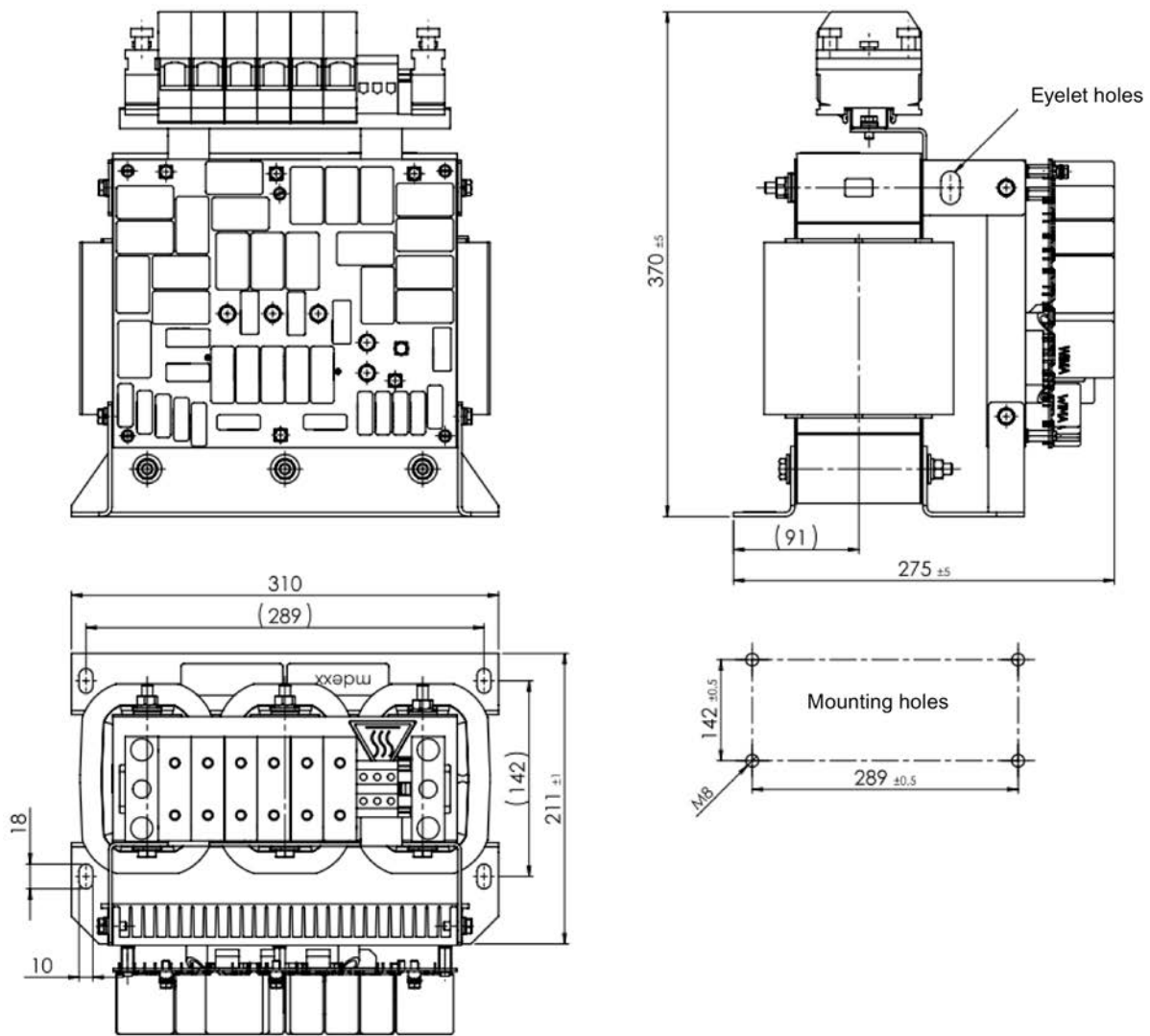

Figure 8-9 Dimensions for JTA:TEF1203-0JB

8.11 dv/dt filter plus VPL

Eyelet holes

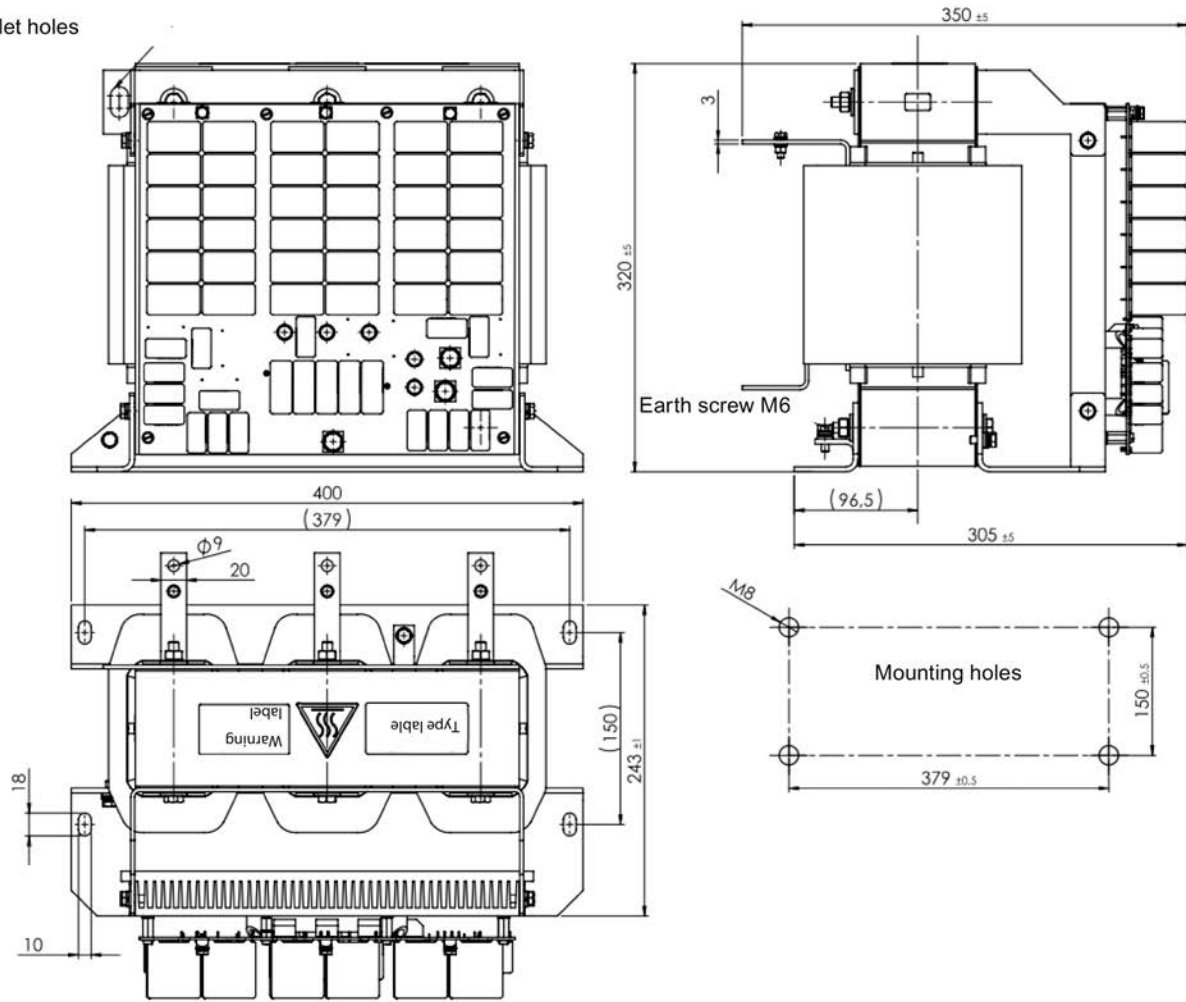

Figure 8-10 Dimensions for JTA:TEF1203-0KB

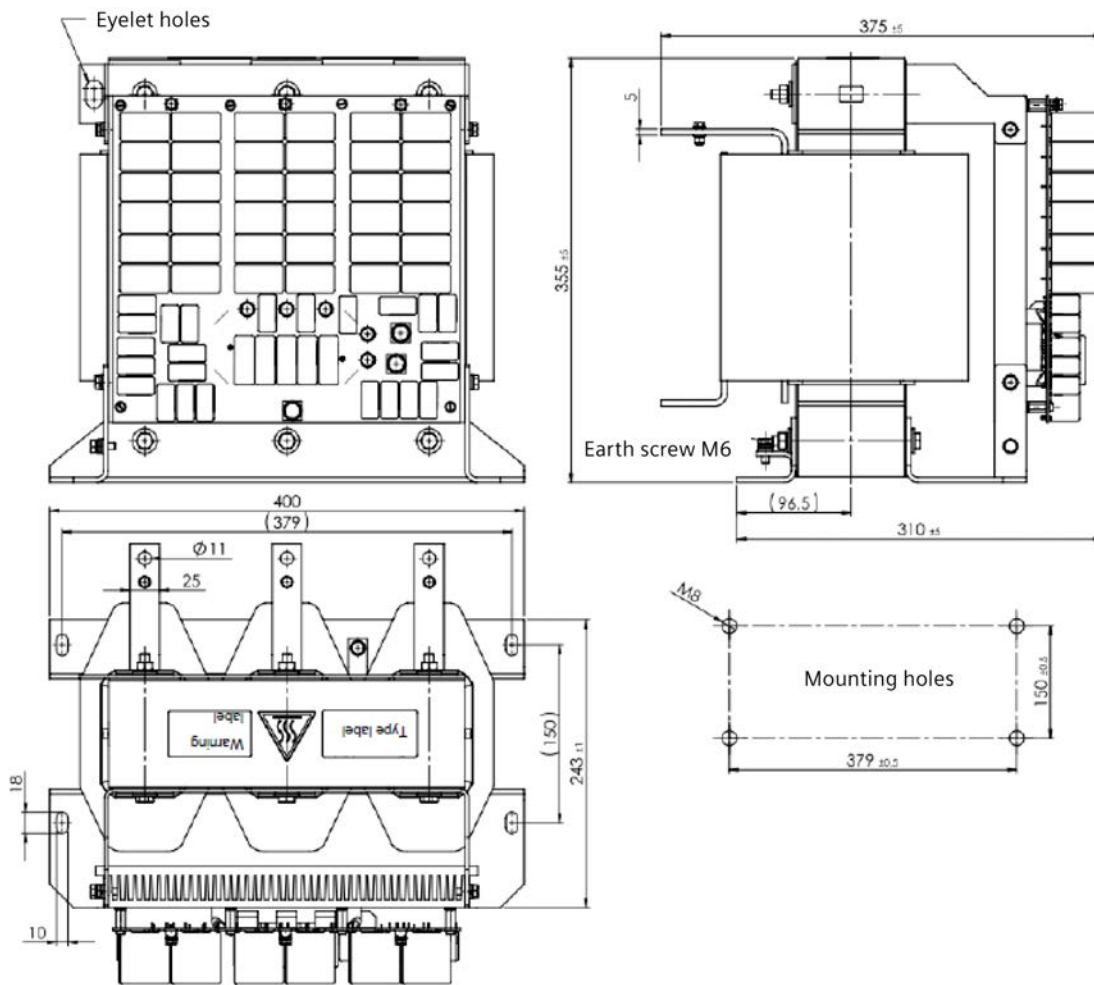

Figure 8-11 Dimensions for JTA:TEF1203-OLB

8.11 dv/dt filter plus VPL

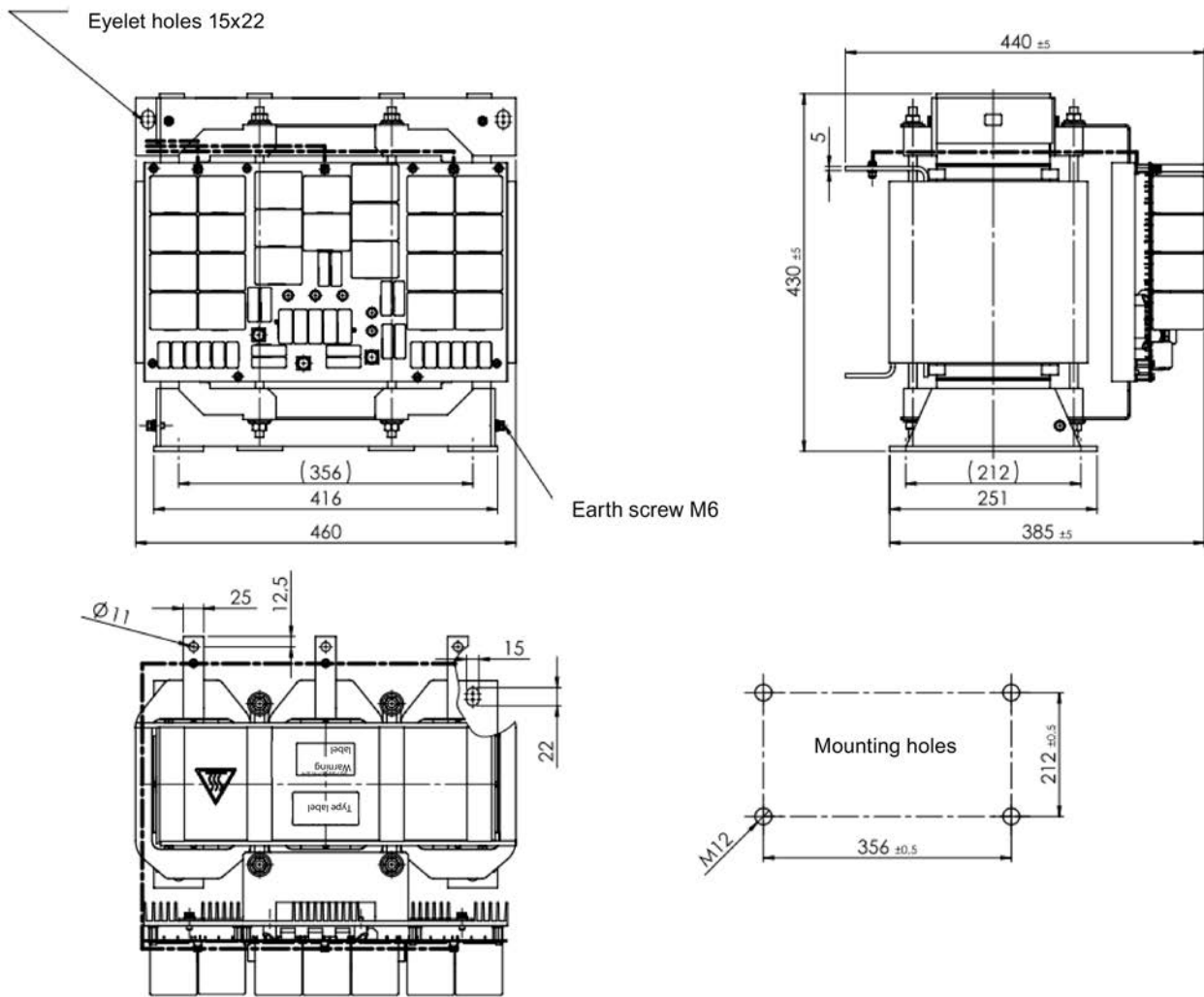

Figure 8-12 Dimensions for JTA:TEF1203-OMB

Technical data

Article number JTA: TEF1203		-0GB	-0HB	-0JB
Rated power		18.5 kW	37 kW	55 kW
Rated voltage (phase to phase)		690 V (+10%)	690 V (+10%)	690 V (+10%)
Rated output current (rms)		24 A	44 A	64 A
Maximum output current (rms)		38 A	70 A	104 A
Inductance (Tolerance \pm 5%)		1.5 mH	1.2 mH	0.9 mH
Winding resistance		3 x 20.9 m Ω	3 x 14.6 m Ω	3 x 10.24 m Ω
Nominal pulse frequency		2 kHz	2 kHz	2 kHz
Maximum pulse frequency		4 kHz	4 kHz	4 kHz
Output current maximum pulse frequency		14.4 A	26.4 A	38.4 A
Maximum output frequency		150 Hz	150 Hz	150 Hz
Voltage drop		17.15 V	17.13 V	17.97 V
Rated DC link voltage		935 V	935 V	935 V
Maximum voltage rise at motor terminals ¹⁾		< 500 V/ μ s	< 500 V/ μ s	< 500 V/ μ s
Maximum peak voltage at motor terminals (phase to phase) ²⁾	@ 400 V	800 V	800 V	800 V
	@ 690 V	1350 V	1350 V	1350 V
Maximum peak voltage at motor terminals (phase to earth) ²⁾	@ 400 V	650 V	650 V	650 V
	@ 690 V	1100 V	1100 V	1100 V
Maximum cable length filter - motor (screened / un-screened)		350 m / 525 m	350 m / 525 m	350 m / 525 m
Terminal type		Screw terminals	Screw terminals	Screw terminals
Rated terminal cross section (load circuit)		16 mm ²	35 mm ²	50 mm ²
Rated terminal cross section (DC link feedback) ³⁾		16 mm ²	16 mm ²	16 mm ²
Degree of protection ⁴⁾		IP00	IP00	IP00
Ambient temperature ⁵⁾		-20°C to 40°C	-20°C to 40°C	-20°C to 40°C
Weight		20 kg	29 kg	46 kg
Connection		Metrical (mm ² / Nm) Imperial (AWG / lbf.in) Stripping length (mm)		
Line / motor cable		16 / 1.2 6 / 11.0 13	35 / 2.5 2 / 22 17	70 / 6.0 2/0 / 53 24
DC link		16 / 1.2 6 / 11.0 13	16 / 1.2 6 / 11 13	16 / 1.2 6 / 11 13
Ground		16 / 1.2 6 / 11.0 13	35 / 2.5 2 / 22 17	70 / 10.0 2/0 / 86 24

¹⁾ Voltage rise according IEC/TS 60034-17

²⁾ Under nominal DC link voltage

³⁾ Short-circuit-proof wiring is required

⁴⁾ Installing the filter in an enclosure is required

⁵⁾ Higher ambient temperatures up to 60°C allowed with current derating at 40°C, in the range 40...50°C with 1.5% per 1K and in the range 50...60°C with 1.9% per 1K

8.11 dv/dt filter plus VPL

Article number JTA: TEF1203	-OKB	-OLB	-OMB
Rated power	90 kW	132 kW	250 kW
Rated voltage (phase to phase)	690 V (+10%)	690 V (+10%)	690 V (+10%)
Rated output current (rms)	103 A	230 A	416 A
Maximum output current (rms)	160 A	70 A	104 A
Inductance (Tolerance \pm 5%)	0.53 mH	0.37 mH	0.22 mH
Winding resistance	3 x 4.9 m Ω	3 x 3.25 m Ω	3 x 1.4 m Ω
Nominal pulse frequency	2 kHz	2 kHz	2 kHz
Maximum pulse frequency	4 kHz	4 kHz	4 kHz
Output current maximum pulse frequency	61.8 A	87.6 A	156 A
Maximum output frequency	150 Hz	150 Hz	150 Hz
Voltage drop	17.2 V	17.1 V	18.0 V
Rated DC link voltage	935 V	935 V	935 V
Maximum voltage rise at motor terminals ¹⁾	< 500 V/ μ s	< 500 V/ μ s	< 500 V/ μ s
Maximum peak voltage at motor terminals (phase to phase) ^{2) 3)}	@ 400 V	800 V	800 V
	@ 690 V	1350 V ... 1500 V	1350 V ... 1500 V
Maximum peak voltage at motor terminals (phase to earth) ²⁾	@ 400 V	650 V	650 V
	@ 690 V	1100 V	1100 V
Maximum cable length filter - motor (screened / unscreened) ³⁾	450 m / 650 m	450 m / 650 m	450 m / 650 m
	525 m / 800 m	525 m / 800 m	525 m / 800 m
Terminal type	Busbar M8	Busbar M10	Busbar M10
Rated terminal cross section (load circuit)	95 mm ²	120 mm ²	2x120 mm ² 1x185 mm ²
Rated terminal cross section (DC link feedback) ⁴⁾	25 mm ²	25 mm ²	50 mm ²
Degree of protection ⁵⁾	IP00	IP00	IP00
Ambient temperature ⁶⁾	-20°C to 40°C	-20°C to 40°C	-20°C to 40°C
Weight	77 kg	97 kg	172 kg
Connection	Metrical (mm ² / Nm) Imperial (AWG / lbf.in)		
Line / motor cable	95 / 13.0 3/0 / 115	120 / 13.0 4/0 / 115	2 x 120 / 13.0 2 x 4/0 / 115 185 / 13.0 6/0 / 13.0
DC link	25 / 9.0 4 / 80	25 / 9.0 4 / 80	50 / 9.0 1 / 80
Ground	50 / 6.0 1 / 53	70 / 6.0 2/0 / 53	95 / 6.0 3/0 / 53

¹⁾ Voltage rise according IEC/TS 60034-17

²⁾ Under nominal DC link voltage

³⁾ Maximum peak voltage at motor terminals < 1350V at cable length up to 450m screened or 650m unscreened
Maximum peak voltage at motor terminals < 1500V at cable length up to 525m screened or 800m unscreened

⁴⁾ Short-circuit-proof wiring is required

⁵⁾ Installing the filter in an enclosure is required













⁶⁾ Higher ambient temperatures up to 60°C allowed with current derating at 40°C, in the range 40...50°C with 1.5% per 1K
and in the range 50...60°C with 1.9% per 1K















Appendix

A.1 Manuals and technical support

A.1.1 Manuals for your converter

Manuals with additional information that can be downloaded:

-  Power Module Installation Manual
<https://support.industry.siemens.com/cs/ww/en/ps/13224/man>
 Installing Power Modules, reactors and filters. Technical specifications, maintenance (this manual)

-  CU230P-2 Compact Operating Instructions
<https://support.industry.siemens.com/cs/ww/en/view/109744767>
 Commissioning the converter

-  CU240B/E-2 Compact Operating Instructions
<https://support.industry.siemens.com/cs/ww/en/view/109744768>
 Commissioning the converter

-  CU250S-2 Compact Operating Instructions
<https://support.industry.siemens.com/cs/us/en/view/109782994>
 Commissioning the converter.

-  CU230P-2 operating instructions
<https://support.industry.siemens.com/cs/ww/en/view/109782866>
 Installing, commissioning and maintaining the converter. Advanced commissioning

-  CU240B/E-2 operating instructions
<https://support.industry.siemens.com/cs/ww/en/view/109782865>
 Installing, commissioning and maintaining the converter. Advanced commissioning

-  CU250S-2 operating instructions
(<https://support.industry.siemens.com/cs/ww/en/view/109482988>)
Installing, commissioning and maintaining the converter. Advanced commissioning

-  "Safety Integrated" function manual
(<https://support.industry.siemens.com/cs/ww/en/view/109751320>)
Configuring PROFIsafe. Installing, commissioning and operating fail-safe functions of the converter.

-  CU230P-2 List Manual
(<https://support.industry.siemens.com/cs/us/en/view/109782303>)
Parameter list, alarms and faults. Graphic function diagrams

-  CU240B/E-2 List Manual
(<https://support.industry.siemens.com/cs/us/en/view/109782301>)
Parameter list, alarms and faults. Graphic function diagrams

-  CU250S-2 List Manual
(<https://support.industry.siemens.com/cs/ww/en/view/109782287>)
Parameter list, alarms and faults. Graphic function diagrams

-  EMC installation guideline
(<https://support.industry.siemens.com/cs/ww/en/view/60612658>)
EMC-compliant control cabinet design, equipotential bonding and cable routing

-  Accessories manual (<https://support.industry.siemens.com/cs/ww/en/ps/13225/man>)
Installation descriptions for converter components, e.g. line reactors and line filters. The printed installation descriptions are supplied together with the components.

A.1.2 Download a Manual

Finding the most recent edition of a manual

If there are multiple editions of a manual, select the latest edition:



Configuring a manual

Further information about the configurability of manuals is available in the Internet:



MyDocumentationManager

(<https://www.industry.siemens.com/topics/global/en/planning-efficiency/documentation/Pages/default.aspx>).

Select "Display and configure" and add the manual to your "mySupport-documentation":

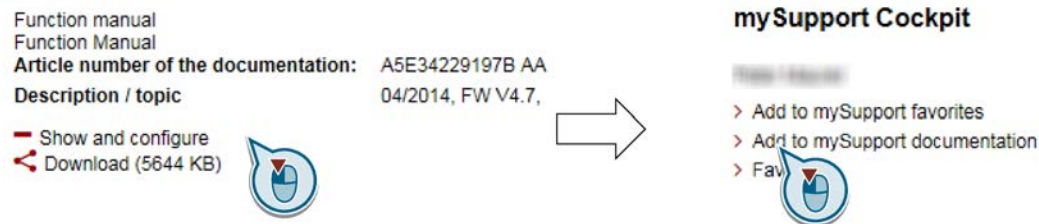

Not all manuals can be configured.

The configured manual can be exported in RTF, PDF or XML format.

A.1.3 Configuring support

Catalog

Ordering data and technical information for the converters SINAMICS G.



Catalogs for download or online catalog (Industry Mall):

 All about SINAMICS G120 (www.siemens.com/sinamics-g120)

SIZER

The configuration tool for SINAMICS, MICROMASTER and DYNAVERT T drives, motor starters, as well as SINUMERIK, SIMOTION controllers and SIMATIC technology



 SIZER on DVD:

Article number: 6SL3070-0AA00-0AG0

 Download SIZER (<https://support.industry.siemens.com/cs/ww/en/ps/13434>)

EMC (electromagnetic compatibility) technical overview

Standards and guidelines, EMC-compliant control cabinet design



 EMC overview (<https://support.industry.siemens.com/cs/ww/en/view/103704610>)

EMC Guidelines configuration manual

EMC-compliant control cabinet design, potential equalization and cable routing



 EMC installation guideline
(<https://support.industry.siemens.com/cs/ww/en/view/60612658>)

A.1.4 Product Support

Overview

You can find additional information about the product on the Internet:

 Product support (<https://support.industry.siemens.com/cs/ww/en/>)

This URL provides the following:

- Up-to-date product information (product announcements)
- FAQs
- Downloads
- The Newsletter contains the latest information on the products you use.
- The Knowledge Manager (Intelligent Search) helps you find the documents you need.
- Users and specialists from around the world share their experience and knowledge in the Forum.
- You can find your local representative for Automation & Drives via our contact database under "Contact & Partner".
- Information about local service, repair, spare parts and much more can be found under "Services".

If you have any technical questions, use the online form in the "Support Request" menu:

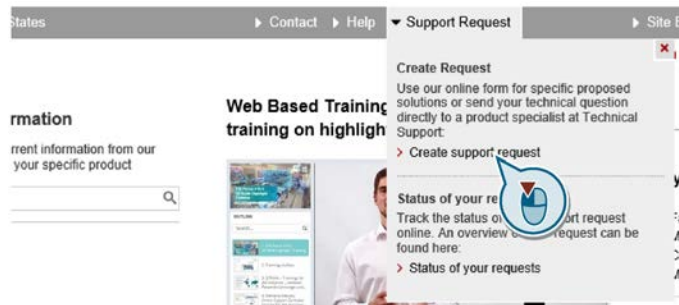

A.2 Directives and standards

The following directives and standards are relevant for the converters:



European Low Voltage Directive

The converters fulfil the requirements stipulated in Low Voltage Directive 2014/35/EU insofar as they are covered by the scope of application of this Directive.

European Machinery Directive

The converters fulfil the requirements stipulated in Machinery Directive 2006/42/EU insofar as they are covered by the scope of application of this Directive.

Use of the converters in a typical machine application has been fully assessed for compliance with the main regulations in this Directive concerning health and safety.

Directive 2011/65/EU

The converter fulfills the requirements of Directive 2011/65/EU relating to the restriction of the use of certain hazardous substances in electrical and electronic devices (RoHS).

European Directive on Waste Electrical and Electronic Equipment (WEEE)

The SINAMICS converter series complies with the 2012/19/EU directive on taking back and recycling waste electrical and electronic equipment.

European EMC Directive

By completely complying with IEC/EN 61800-3, it has been proven that the converter is in compliance with Directive 2014/30/EU.



UK Declaration of Conformity

The converter complies with the requirements for the market in Great Britain (England, Wales and Scotland).



Underwriters Laboratories (North American market)

Converters bearing one of the certification marks shown on the left meet the requirements for the North American market as a component of drive applications and are listed correspondingly.





EMC requirements for South Korea

The converters with the KC marking on the rating plate satisfy the EMC requirements for South Korea where necessary by means of additional RFI suppression filter (EMC filter).



Eurasian conformity

The converters comply with the requirements of the Russia/Belarus/Kazakhstan customs union (EAC).



Australia and New Zealand (RCM formerly C-Tick)

The converters bearing the certification mark shown here meet the EMC requirements for Australia and New Zealand.

Specification for semiconductor process equipment voltage drop immunity

The converters comply with the requirements of standard SEMI F47-0706.

Quality systems

Siemens AG employs a quality management system that meets the requirements of ISO 9001 and ISO 14001.

DNV GL ^{1) 2)}

The converters comply with the requirements of DNV GL for classification – ships, offshore units, and high speed and light crafts.

¹⁾ For converters FSD ... FSG, the Control Unit Adapter Kit CUA20 is required to fulfill the requirement.

²⁾ For converters FSA ... FSC with CU250S-2, the Control Unit Adapter Kit CUA20 is required to fulfill the requirement.

China RoHS

The converters comply with the China RoHS.

You can find additional information at:

China RoHS (<https://support.industry.siemens.com/cs/ww/en/view/109775641>)

A.3 Abbreviations

Abbreviation	Explanation
AC	Alternating current
CE	Communauté Européenne
CU	Control Unit
DC	Direct current
DI	Digital input
DIP switch	DIP switches are small switches, found mostly on PBCs, for making basic device settings
DO	Digital output
ECD	Equivalent circuit diagram
EEC	European Economic Community
ELCB	Earth leakage circuit breaker
EMC	Electromagnetic compatibility (EMC)
EMI	Electromagnetic interference
FS...	Frame size ...
HO	High overload
I/O	Input/Output
IGBT	Insulated gate bipolar transistor
LED	Light emitting diode
LO	Low overload
NC	NC contact
NEMA	National Electrical Manufacturers Association
NO	NO contact
OPI	Operating instructions
PELV	Protective extra low voltage
PM	Power Module
PPE	Personnel protective equipment
RCCB	Residual-current operated circuit breaker
RCD	Residual current device
RFI	Radio frequency interference
SELV	Safety extra-low voltage
VPL	Voltage Peak Limiter; component for limiting voltage peaks

Index

8

87 Hz characteristic, 64

A

Air barrier, 31

B

Base load, 76

Base load input current, 76

Base load output current, 76

Base load power, 76

Brake Relay, 142

Braking resistor

Clearances, 132

Dimension drawings, 134

Installation, 132

C

Catalog, 170

Category C2, 54

Category C3, 54

Clearances, 132

Commutation dips, 128

Configuring support, 170

Cooling, 31

D

Delta connection, 63

Derating

Installation altitude, 106

Dimension drawings, 129, 134, 147, 149, 151

Drilling pattern, 129, 134, 149, 151

E

Electrical installation, 41

EMC, 25

F

Field weakening, 63

Function Manual, 167

G

Getting Started, 167

H

Hardware Installation Manual, 167

Harmonic currents, 111

Harmonics, 111, 128

High Overload, 76

Hotline, 171

I

Industry Mall, 170

Installation altitude, 106

Installing, 32

IT system, 44

L

Line reactor

Dimension drawings, 129

Line supply type, 44

List Manual, 167

Low Overload, 76

M

Maintenance

Cleaning, 66

Dirt, 66

Pollution, 66

Terminals, 66

Ventilation, 66

N

Neutral conductor, 44

Number of starting operations, 73

O

Operating instructions, 167
Output reactor
 Dimension drawings, 147, 149, 151
Overvoltage protection, 128

P

Partial load operation, 78
Power distribution systems, 44
Protective conductor, 44

Q

Questions, 171

S

Safe Brake Relay, 142
Safety notes
 Electrical installation, 41
Service life of the fan, 68
SIZER, 170
Standards
 EN 61800-3, 172
Star connection (Y), 63
Support, 171

T

Tightening torque, 129
TN system, 44
TT system, 44

Further information

SINAMICS converters:
www.siemens.com/sinamics

Industry Online Support (Service and Support):
www.siemens.com/online-support

Industry Mall:
www.siemens.com/industrymall

Siemens AG
Digital Industries
Motion Control
P.O. Box 3180
91050 Erlangen
Germany

Scan the QR code
for additional
information about
SINAMICS G120.

